

## **PREFACE AND ACKNOWLEDGMENTS**

This Rule Book is a joint effort of the two Donkey and Mule Clubs of Texas:

**Southwestern Donkey & Mule Society**  
**Gulf Coast Donkey & Mule Association**

These two organizations have recognized the need for unity of rules throughout the state of Texas to eliminate confusion for exhibitors when participating at shows in different regions, and, most importantly, to combine and share the knowledge and experiences of both clubs in a unified effort to promote the donkey and mule to its fullest potential. A Rules Committee made up of 7 member representatives from each club will meet, or in some way communicate, in April of each even numbered year to vote on improvements, changes, additions or deletions as needed. While these representatives will be acting on behalf of their own individual club needs and goals, their primary responsibility will be to the "group" in a spirit of compromise and an effort to be fair and impartial. The decision of the Committee will be final.

Appreciation is extended to the club members from the two organizations who have met formally and/or by phone and e-mail during the time it has taken to put this current rule book together. It is through their efforts, cooperation and patience that this ninth edition of The Rule Book for the Texas Donkey and Mule Organizations has been completed.



### **Calendar for Even Numbered Years:**

**Feb 15 All proposed rule changes must be exchanged by the proposing club to all other clubs.**

**No changes will be allowed after this date.**

**April Rules Committee meeting**

**May Final draft available to clubs**

**Nov New Rule Book Editions to clubs**

**2014 New Rule Book printed**

# The Texas Donkey and Mule Organizations Rule Book 2015

## CONTENTS

### I. GENERAL RULES & DEFINITIONS

1.1 Show Management.....	7
1.2 Show Procedures.....	8
1.3 Entries .....	10
1.4 Judges.....	11
1.5 Arena Conditions & Usage.....	12
1.6 Points .....	13
1.7 Misconduct/Abuse .....	14
1.8 Definitions.....	15
A. Mule.....	15
B. Draft Mule.....	16
C. Gaits - Western Performance.....	16
D. Gaits - English Performance.....	16
E. Pee-Wee.....	17
F. Sub-Youth.....	17
G. Youth.....	18
H. Adult.....	19
I. Novice.....	19
J. Green.....	20
K. Open.....	22
L. Western Performance Class.....	22
M. Age of Animal.....	22
N. Amateur.....	23
O. Beginner.....	25
P. Select.....	25

### II. ATTIRE

2.1 Halter, Western Performance, Speed Events and Cattle Classes .....	26
2.2 English Performance Classes.....	26

2.3	Driving Classes.....	27
2.4	Exceptional Attire.....	27

**III. EQUIPMENT**

3.1	Halter Classes.....	28
3.2	Western Performance Classes.....	28
3.3	English Classes.....	30
3.4	Speed Events and Cattle Classes.....	35
3.5	Driving Classes .....	36
3.6	General Equipment Rule.....	37
3.7	Illegal Bits for All Classes.....	37

**IV. CLASS RULES - HALTER**

4.1	Halter Classes.....	37
4.2	Additional Halter Classes .....	39

**V. CLASS RULES – SHOWMANSHIP**

5.1	Showmanship Classes .....	40
-----	---------------------------	----

**VI. CLASS RULES - DRIVING..**

6.1	General Driving Rules.....	44
6.2	Single Hitch Driving .....	45
6.3	Single Hitch Obstacle Driving.....	46
6.4	Single Hitch Timed Driving .....	47
6.5	Multiple Hitch Driving .....	47
6.6	Multiple Hitch Obstacle Driving.....	48
6.7	Parade Class.....	49
6.8	Reinsmanship.....	49
6.9	Gambler's Choice Driving .....	50
6.10	Versatility Ride and Drive .....	51
6.11	Snigging.....	52
6.12	Log Dragging.....	54
6.13	Suggested Obstacles.....	56

**VII. CLASS RULES - WESTERN PERFORMANCE**

7.1	General Western Performance Class.....	56
7.2	Western Pleasure .....	57

7.3 Trail Class .....	59
7.4 Lead Line Obstacle .....	66
7.5 Reining.....	66
7.6 Reined Working Donkey .....	82
7.7 Western Mulemanship/Donkeymanship....	82
7.8 Western Riding.....	84
7.9 Command Class .....	89
7.10 Ranch Riding .....	91

**VIII. CLASS RULES -ENGLISH PERFORMANCE**

8.1 General English Performance Class Rules....	95
8.2 Hunter Under Saddle.....	95
8.3 Hunter Hack.....	96
8.4 Hunt Seat Equitation.....	97
8.5 English Pleasure .....	99
8.6 Working Hunter .....	100
8.7 Jumping .....	102

**IX. CLASS RULES-SPECIALTY PERFORMANCE CLASSES**

9.1 General Specialty Class Rules.....	108
9.2 Coon Hunters Jumping .....	108
9.3 Costume Class .....	109
9.4 Freestyle Reining .....	110
9.5 Side Saddle.....	111

**X. CLASS RULES SPEED EVENTS**

10.1 General Speed Event Rules.....	113
10.2 Straight-Away Barrels.....	113
10.3 Cloverleaf Barrels.....	114
10.4 Pole Bending .....	115
10.5 Keyhole Race.....	117
10.6 Pylon Alley .....	118
10.7 Potato Race (Baseball Race).....	118
10.8 Flag Race .....	121
10.9 Egg Race.....	121
10.10 Egg in Spoon Ride .....	118
10.11 Ride a Buck .....	120

10.12 Hurdle Race .....	120
10.13 Tunnel Race.....	120
10.14 Hide Drag .....	122
10.15 Boot Race.....	121
10.16 Sack Race .....	122
10.17 Old Clothes Race.....	122
10.18 Rescue Race .....	123
10.19 Stake Race .....	123
10.20 Run, Ride and Lead.....	124
10.21 Gambler's Choice Trail .....	124

**XI. CLASS RULES - CATTLE CLASSES**

11.1 General Cattle Class Rules.....	128
11.2 Steer stopping (timed).....	128
11.3 Team Roping (timed).....	129
11.4 Buffalo Hunt (timed).....	129
11.5 Working Cow Mule (judged).....	129

**XII. MULE PULLS**

12.1 Management Requirements.....	136
12.2 Pull Rules.....	136

**MINIATURE DONKEY and MULE SECTION**

1. Show Regulations .....	140
2. Ring Procedures .....	143
3. Exhibitor Show Age .....	144
4. Awards – Halter Champion .....	145
5. Performance Champion .....	145
6-13. Class List.....	146
14-18. Halter Class Rules .....	149
19-24 Unassigned	
25. In Hand Jumping .....	151
26. Coon Jumping .....	153
27. Lead Race .....	155
28. Lead Obstacle Race .....	155

29. Pre-Green, Green, Open Hunter .....	156
30. Snigging .....	157
31. Log Drag .....	158
32-39. Unassigned	
40. General Driving Rules .....	162
41. Clarification of Pleasure Driving Gaits .....	164
42-51. Performance Driving Classes .....	165
52-55. Game Driving Classes .....	170
56-69. Unassigned	
70. In-Hand Trail .....	173
71. Versatility Class .....	177
72-79. Unassigned	
80-83. Showmanship .....	178
84-89 Unassigned	
90. Pee-wee Division .....	183
91. Costume Class .....	183
92. Additional Classes .....	184
<b>Index.....</b>	<b>185</b>

# **I. GENERAL RULES & DEFINITIONS**

## **1.1 Show Management**

- A. Ring Steward: The ring steward has charge of the activities in the arena. He/she is the mediator between the judge and the exhibitor. No one may ask or question a judge about his/her decision or class placings except through the ring steward. (An exhibitor who confronts the judge directly without permission from the ring steward **WILL BE DISQUALIFIED**). The ring steward has the right and authority to disqualify or excuse any exhibitor from any class or from the remainder of a show for reasons of unsportsmanlike conduct, misconduct, safety, animal abuse, soundness and/or a violation of the rules. In such instances, all accumulated points shall be forfeited for that show at the discretion of the ring steward and Hearing Committee. The ring steward may assist an exhibitor when asked to trot in a halter class without any point deduction.
- B. Show Hearing Committee: Every sanctioned show must have a designated Hearing Committee of at least 3 club members on the grounds during the entire show to make immediate decisions based on the current Texas Donkey & Mule Organizations Rule Book in case of a protest during the show. These members should be familiar with the rules and able to make unbiased decisions based on the rules.
- C. Class Management: Show management reserves the right to combine or cancel any class due to lack of entries, hazardous conditions, or acts of nature. Entry fees in these situations may be refunded or show may be rescheduled.
- D. Protests: Protest of any activity, in or out of the show ring, will be directed to the Show Hearing Committee. Protests must be written and accompanied by a \$50.00 fee. Protests, involving a class, can only be made by an exhibitor participating in that class. The protest fee will be refunded if the protest is upheld by the Hearing Committee. All Hearing Committee decisions are final. A protest must be made within 48 hours after completion of the show. Judge's decisions are not subject to a protest.
- E. Refunds: Refunds will be at the discretion of show management. Any refund of entry fees may be made by mail from the show office.
- F. Rule Reference: The current year AQHA and NMDA Rule Books will

be used as a point of reference for the Texas Donkey and Mule Organizations. However, it is to be understood that the Texas Donkey & Mule Organizations do not necessarily follow all AQHA or NMDA rules.

- G. Judge/Exhibitor procedures: If any exhibitor in any way whether in person or by agent or servant, interferes with the judge during their adjudication, or shows disrespect to them or the show, the show management may exclude him/her from competition, and withhold any prizes that may have been awarded. Any person who wishes to address a situation or problem involving the judge **MAY NOT** contact the judge directly during a class in progress. They may go to the Ring steward, or show management.
- H. If there are rules for a class in the current Texas Rule Book, that rule must be used and cannot be superseded by a special show rule or a rule from another rule book.

## 1.2 Show Procedures

- A. A "sanctioned show" is one that fulfills all the requirements of the Regional donkey and mule club allocating the sanction. A "sanctioned show" will generally count for year-end points for the Regional Club.
- B. There may be halter classes, performance classes, and timed events at each show to count for points for High Point awards, which will also count toward Year End Awards. (Generally: Donkey, Mule, Youth Donkey, Youth Mule, Sub-Youth, plus others as warranted). There may also be separate awards recognizing divisions as stated above or additional divisions as appropriate to and chosen by the Regional Club. An Overall High Point donkey and mule must be recognized at each show (announcement, plaque or better).
- C. The show flyer should be **mailed or posted online** a minimum of 30 days prior to show date and should state the name of the organization hosting and sanctioning the show, and it is recommended that it state the following:
1. Award Divisions and classes which apply to each Division (Double Check for ACCURACY!)
  2. Awards being offered for each Class, Division, Overall
  3. Entry information: Class fees and pre-entry and/or entry closing date
  4. Name of judge(s)

5. Location/directions (map if appropriate)
6. Day(s), Date(s), and Starting time of Show/Special events (each day if applicable)
7. Availability of stalls, RV hookups, and motels
8. Covered or uncovered arena
9. Concession available on grounds or not
10. Name, address and phone number of person(s) to contact for further information
11. The following statements added to the flyer could prevent the most common problems which occur with new members or exhibitors not familiar with the Rule Book:
  - a. An animal may be shown in only one point earning halter class.
  - b. Youth may show only in classes designated "Youth" or "Open" and in any halter class (may not show a jack except as noted in Miniature Donkey and Mule section).
  - c. An animal may not be entered in both "Green" and ("Adult") Western Performance Classes if that class is offered in Green division, but may enter any Open classes.
  - d. An exhibitor may not show an animal 36.01" and over in both "Novice" and ("Adult") Western Performance Classes if Novice classes are offered at that show, but may any enter Open classes.
  - e. A "Green" animal 36.01" and over may be shown in both "Green" and "Novice" classes.
  - f. A Miniature Donkey or Mule shall not compete in both Green and Open classes at the same show if both divisions are offered. See the Miniature Donkey and Mule section rules regarding specific divisions.
  - g. Refer to the Miniature Donkey and Mule section for restrictions related to the Pre-green Miniature Donkey division.
12. State any Division gait limitations (i.e. trot only for Novice or Green).
  - D. All non-point halter Classes for donkeys and mules (all sizes and colors) must be scheduled after the point earning halter classes are completed.
  - E. Class call: All classes will be called three (3) times only. Class will close 2 minutes after the first animal enters the show arena. If sufficient entries warrant, the gate may remain open until the last exhibitor enters the ring, as long as there is a continuous flow of entries into the ring. Consideration will be given only when a tack change is involved, in which case, the exhibitor must inform the gate keeper upon leaving one class that time will be needed for a tack

change before re-entering for the next class. Once the class is closed, the gate will be closed and remain closed until judging is complete.

F. Judge's Options - The judge may ask to mouth the animal or inspect tack. The judge may ask for an animal in any class to deviate from the printed pattern only if it is necessary in determining a winner. Prime consideration will be given to the safety of the animals, exhibitors and spectators. The judge's decision is final.

G. Timers: Electronic timers should be used for all timed events. If an electronic timer is not available a minimum of two stop watches and two timers are required. One will be designated the official timer and one the backup.

H. Jacks 36.01 and over will not be shown by Youth or Sub-Youth. See Miniature Donkey and Mule section concerning youth showing Miniature jacks.

I. Patterns for performance classes (i.e. Showmanship, Driving, Western and English) will be posted no less than 1 hour prior to the class itself. Patterns for Reining and Working Cow Mule may be designated on show flyer. Patterns for timed events or any classes not listed in Rule Book, or listed in Rule Book but with variations, should be posted prior to entry and on show bill so prospective contestants will understand what they are entering. . **Patterns may be posted on the website prior to the start of the show, or at the venue no less than 1 hour prior to the class itself.**

J. It is NOT recommended that donkeys and mules compete against each other except in Sub-Youth classes or costume classes.

### **1.3 Entries**

A. Each individual animal must be assigned only ONE entry number. (For convenience, an exhibitor may create any number of legible copies of the issued number.) Animals shown in pairs (or 4-ups, etc.) can be issued a separate number for that particular pair (or unit) only. Switching or substituting animals assigned a unit number will result in immediate disqualification.

B. The correct entry number must be visible on the exhibitor or animal to participate in the class (only one number should be visible in single

animal classes). Failure to display correct number **will** result in disqualification.

- C. Entries will close 2 classes prior to the class entered unless superseded by the general rules of the governing show.
- D. Show office hours will be posted at each show.
- E. If there is only one entry in a class, that entry must still complete the competition and be judged. The judge may place a single entry in a position other than first place at his option.
- F. An animal may be ridden or driven only once per class. (Exception: Team Roping)
- G. In eliminations, an animal must be ridden or driven by the same exhibitor who participated in the original class.
- H. Owners will be responsible for the correct measurement of their animal and for entering in the proper class. A measurement stick (with level) will be available to assist owner, if necessary. Measurements will have no allowance for shod or unshod animals.

## **1.4 Judges**

- A. Approval of all judges must be given by the Regional Club.
- B. A biography and/or list of judging credentials is recommended to be obtained on each approved judge and made available to exhibitors, if requested, prior to the day of the show.
- C. No judge may judge any related person or any animal that person owns.
- D. No judge may judge any animal they have an interest in or have owned, trained or sold in the past six months.
- E. A judge may judge only one show per year per Regional Club.
- F. No judge may judge the same show more than two consecutive years.
- G. The Judge shall be present during all timed events and is responsible for all fault deductions and eliminations.

H. Regional Clubs may elect to use multiple judges for its shows. Each judge will meet all requirements listed above. Each judge will score the exhibitors individually and placing will be announced for all judges. Judges will be titled A< B< etc. Each judge will alternate classes to be assigned the tie breaking decision. Regional clubs will determine the method of calculating high points at their respective shows. Show points from all judges may be totaled and one high point awarded for each division or, at the club's discretion, a high point award may be given for each judge. It is suggested that ribbons for each judge be awarded for each class. It is recommended that an announcement be given by the regional club to its members to advise of the tabulation system used for year-end points for multiple judged shows.

## **1.5 Arena Conditions & Usage**

- A. All gates to the arena shall be closed during the running of every event. No gate shall be opened until the rider or riders have completed the course or class. A means shall be made to close openings to roping chutes, if applicable.
- B. Classes or Divisions listed below are BEST HELD when dirt conditions are packed and hard. Surface should be BEST dressed with a drag to appear smooth and level.
  - 1. Halter Classes
  - 2. Showmanship
  - 3. Driving Classes
  - 4. Pulling (pulling lanes need to be EXTRA hard for the best pull)
  - 5. All Miniature Classes.
- C. All other divisions, except for Gymkhana, SHOULD BE lightly disked.
- D. Gymkhana events SHOULD NOT BE HELD UNTIL THE ARENA HAS BEEN DISKED. If applicable due to large classes, re-disking should occur between every 10 contestants or less, as conditions warrant, to prevent falls.
- E. It is preferred and suggested that the entire established (by fence or some type of barrier) arena perimeter will be used by every class for animals 36.01" and over. Using half the arena for in-hand miniature classes is preferred. Judges will have the option of requesting the use of only half of the established arena in classes with few contestants.

## 1.6 Points

A. Accumulation of points for shows and year end awards will be determined by the following system:

No. of Animals	1 <sup>st</sup>	2nd	3rd	4th	5th	6th
6	6	5	4	3	2	1
5	5	4	3	2	1	
4	4	3	2	1		
3	3	2	1			
2	2	1				
1	1					

B. Where there are two or more animals in an entry (matched pairs, multiple hitches, etc.) points will be awarded equally to each animal in the entry.

C. Ties are to be broken as indicated below:

1. Classes - Timed Events - There will be a run-off.

2. Divisions - Timed Events: (i.e. Gymkhana, Cattle) Number of first places lowest overall time (must have a qualifying time in each class)

3. Other Divisions (i.e. Miniature Performance, Western Performance, English, Driving, Specialty) and High Point

Number of first places

Number of animals placed over\_\_ (Point Sheets should indicate total number of animals judged in each class)

Number of classes placed in

Then by highest placing in one appropriate division class

(Western Performance: Western Pleasure / English: Hunter Under Saddle / Driving: Pleasure Driving / Miniature Open and Green Division: Pleasure Driving / Miniature Pre-Green Division : Pre-green Trail). **If using the above criteria does not show a definite winner, a coin flip will decide the high point winner and reserve.**

(Specialty Division tie-breakers should be posted at the show)

D. High Point for Youth, Sub-Youth and Novice exhibitors will be tallied on a one youth/one animal combination.

E. Jackpot class money pay-out:

(Team Roping - one team is considered one entry)

Two Entries	1 money	100%
Three Entries	2 monies	60% - 40%
Four or More Entries	4 monies	40%-30%-20%-10%

## 1.7 Misconduct/Abuse

- A. Alcohol or Controlled Substance Usage (Human) - Any exhibitor, exhibitor's family members or their guests appearing to be under the influence of alcohol or a controlled substance will be removed from the show grounds, and the exhibitor will forfeit all entry fees and points earned for that show.
- B. Substance Usage (Animal) - It is strictly forbidden by all Texas Donkey and Mule Organizations for any animal to be exhibited while under the influence of depressants, stimulants or behavioral altering substances.
1. The entry of an animal in any class indicates permission by the exhibitor for an authorized person (either a person trained in proper veterinary procedures or a state certified veterinarian), upon the request of show management, to take a specimen of urine, saliva, blood, or other substance for testing. Any refusal to comply with such request shall constitute grounds for immediate disqualification of the animal from further participation at the show, and shall bar the animal from participation in future Texas Regional Clubs sanctioned events as determined by the Regional Clubs Show Committees.
  2. It is the expressed intent of the Texas Donkey and Mule Organizations to bar any owner, handler or both found guilty of using forbidden substances from competing in any Texas sanctioned event for a minimum period of one year and/or a \$500 fine for the first offense.
  3. Any accumulated points will be forfeited.
- C. Upon a report or discovery of inhumane treatment of an animal, the designated Show Hearing Committee shall immediately investigate the incident.
1. The standard by which conduct or treatment will be measured is that which a reasonable person, informed and experienced in generally accepted equine training and exhibition procedures, would determine to be cruel, abusive or inhumane.

2. Depending upon the situation, an exhibitor and animal may be excused from the remainder of the show with no refund, including the stripping of any points earned to that point; or the exhibitor could be barred from further competition but the animal could be allowed to continue with another exhibitor.
3. Depending upon the situation, the designated Show Hearing Committees of all the Regional Texas Donkey & Mule Clubs have the right to determine if the exhibitor involved in inhumane treatment should be barred from further showing in all sanctioned Texas shows and for what length of time.
4. The Exhibitor has a right to be part of the Hearing and to present his own case.
5. The final decision of the Show Hearing Committee(s) cannot be protested.
- D. Any show related comments, complaints or questions should be made in written form and submitted to the Show Chairman. Any like situations pertaining to the organization as a whole, should also be in written form and submitted to the organization's secretary.
- E. No exhibitor will be allowed to wear any type of official identification while participating in any competition.

## **1.8 Definitions**

- A. MULE - THE HYBRID RESULT OF A CROSS BETWEEN A HORSE AND A DONKEY (EITHER MULE OR HINNY).
1. Halter classes: A "mule" may be shown in any halter class designated "Mules". The result of any other crossing of species of equines must be shown in a separate halter class, which could be designated as "Exotic" or "Zebra Mules".
2. Performance classes: "Mule" performance classes are open only to "mules" as defined in "A" above. Separate performance classes for "Exotic Mules" can be set up by show management as warranted by animals in the area.

## B. DRAFT MULE

1. Mules participating in draft classes must be 56" and over, from a draft or draft-cross mare with the appearance of a work animal.
2. Generally, heavier boned, more muscling overall, but especially in chest and hindquarters; usually thicker necked and with a larger foot.
3. Should the need arise in a particular show area, special classes can be established for draft type mules under 56" but they should not be mixed with draft mules as stated above. If no special classes exist, animals under 56" should show in other available non-draft classes.

## C. GAITS - WESTERN PERFORMANCE

1. Walk - A natural, flat-footed, four-beat gait. The animal must move straight and true at the walk. The walk must be alert, with a stride of reasonable length in keeping with the size of the animal.
2. Jog - A smooth, ground-covering two-beat diagonal gait. The animal works from one pair of diagonals to the other pair. The jog should be square, balanced and with a straight, forward movement of the feet. Animals walking with their back feet and **jogging** on the front are not considered performing the required gait. When asked to extend the jog, the animal moves out with the same smooth way of going.
3. Lope - An easy, rhythmical three-beat gait. Animals moving to the left should lope on the left lead. Animals moving to the right should lope on the right lead. Animals traveling at a four-beat gait are not considered to be performing at a proper lope. The animal should lope with a natural stride and appear relaxed and smooth. Head should be carried at an angle that is natural and suitable to the animal's conformation at all gaits.

## D. GAITS - ENGLISH PERFORMANCE

1. Walk - A natural, flat foot, four-beat gait. The animal must move straight and true at the walk. The walk must be alert, with a stride of reasonable length in keeping with the size of the animal. Loss of forward rhythmic movement shall be penalized.

2. Trot - a two-beat gait comprised of long, low, ground-covering, cadenced and balanced strides. Smoothness is more essential than speed. The knees should remain relatively flat, exhibiting minimal flexion. Short, quick strides and/ or extreme speed shall be penalized. When asked to extend the trot, there should be a definite lengthening of the stride.
3. Canter - a three-beat gait; smooth, free moving, relaxed and straight on both leads. The stride should be long, low and ground covering. Over-collected four-beat canter is to be penalized. Excessive speed is to be penalized.
4. Hand gallop - should be a definite lengthening of the stride with a noticeable difference in speed. The animal should be under control at all times, and be able to halt in a smooth, balanced manner.

#### E. Pee-Wee

1. Pee-Wee exhibitors shall be 5 years and younger. Age to be determined as of January 1.
2. A pee-wee may elect to show in sub-youth classes but not in both. Once a pee-wee voluntarily moves up to sub-youth classes they cannot return to the pee-wee classes.
3. If pee-wee is not offered the exhibitor may show in sub-youth classes without losing their pee-wee eligibility.
4. Pee-wee classes are judged but not placed. All exhibitors are given an equal award.

#### F. Sub-Youth--If Sub-Youth division is not offered at a show, the exhibitor may show in Youth classes without losing their eligibility.

1. Exhibitors 5 to 10 years as of January 1 of the current year. Younger than 5 may compete in specialty classes such as pee-wee when offered.
  - a. A 5 year old exhibitor may elect to compete either as a sub-youth or pee-wee, not in both divisions at the same show. Swapping between sub-youth/pee-wee at different shows is allowed.
2. A Sub-Youth age exhibitor may elect to show in the Youth classes,

but not in both.

3. A Sub-Youth who has shown in Sub-Youth classes in a current year may elect to advance to Youth classes (or if having advanced, return to Sub-Youth classes) but will forfeit all accrued points with any change.
4. A Sub-Youth may show only in Sub-Youth classes except for the Costume Class.
5. Points will be tallied on one sub-youth/one animal combination.
6. A Sub-Youth must be capable of handling the animal alone at all times, but each Sub-youth must have an Adult representative who will remain in a designated area in the show ring should an uncontrollable instance arise. Dress code applies to representative.
7. A Sub-Youth may not show a jack.
8. No Sub-Youth will be asked to lope in any class.
9. In all riding classes, a saddle must be used, and tack must be suitable to size of rider.
10. The suggested classes for non-miniature Sub-Youth are: Showmanship, Western Pleasure-Walk/Trot Riding, Trail - 3 Obstacles. See Class Rules for further descriptions.
11. Any Sub-Youth class may combine donkeys and mules (to be noted on show flyer).
12. Sub-youth Miniature See also Miniature Section.

#### G. Youth

1. Exhibitor 18 years or younger as of January 1 of the current year. See also Miniature Section.
2. Points will be tallied on one youth/one animal combination.
3. A Youth may not show a jack.
4. Youth may show in both Youth donkey and mule classes.

5. Youth exhibitors may show animals in any halter class including a mixed gender class where adults are showing jacks. Classes open to Youth exhibitors (other than Youth classes) will be designated "Open" on show program.

H. Adult - 19 years or older as of January 1 of the current year.

I. Novice

1. An inexperienced ADULT rider.

2. A rider is no longer considered a Novice when they have received **five (5) year end High Point awards from either one of the regional clubs in any 5 calendar years. At the end of five years any individual may petition SDMS Rules Committee or GCDMA Novice Committee to be granted another two years in Novice. Exhibitors who have graduated to Open in 2013 or 2014 may have the opportunity to return to the Novice class, but must retain credit for the two previous years of winning High Point.**

The Novice classes should be offered, when possible, to allow those who consider themselves as beginning riders some special classes in which to only compete with their peers.

3. In shows offering Novice classes, a person must choose between a Novice or Adult class of the same type. (I.e. may not enter both Adult Trail AND Novice Trail). In shows not offering Novice classes, a person may enter any classes they desire without affecting their ability to return to Novice classes when offered.

4. Should any problems arise at a show regarding entries in Novice classes, those problems should be handled just as in Rule 1.8 J. 11.

5. A Novice may ride a Green animal in Novice designated classes. (This will not affect the animal's "Green" status but being shown in Novice classes will count toward the animal's two year limitation.)

6. Although it is NOT recommended to show donkeys and mules in the same class, they may be combined for Novice classes if designated as such on the show flyer.

7. Suggested classes: Showmanship, Western Pleasure or Walk/Trot, Trail.

8. Points will be tallied on a one rider/one animal combination.

J. GREEN – ANIMALS 36.01” AND OVER; SEE MINIATURE SECTION FOR RULES GOVERNING GREEN MINIATURE DONKEYS AND MULES.

1. "Green" designation refers to the animal - any age involved in Performance Classes.
2. Rules 3 through 10 refer to a Green Performance Division. Show management can add other types of Green classes in addition to the 3 required for the Performance Division as is indicated in their area and entitle the expanded division simply "Green Division". Any animal which qualifies for the Green Western Performance classes would also qualify for any additional Green classes (i.e. English or Driving). In regard to the expanded Green classes, an animal cannot be shown in both Green and non-Green classes of the same type at a show (i.e. choose either Green Hunter Hack or Hunter Hack). To avoid confusion, show management should not use the term "Green" if the rules for entry in the classes do not comply with the requirements stated in rules 3-8 below. Other classes can be set up as non-point classes with rules stated on show flyer, (i.e. titled Futurity Class, etc.)
3. Green status begins upon entry in its first Performance riding or driving class in any **Sanctioned Donkey and Mule** show.
  - a. The beginning of Green status includes classes in all categories: Adult, Novice, Youth, Sub-youth and Open since the equipment / hand rules affect all.
  - b. Green status is NOT affected by participation in halter, showmanship, or any non-point earning classes.
4. TIME LIMIT for participation as Green:  
2 Calendar years (Jan-Dec)
  - a. First calendar year begins with participation in the first Performance riding or driving class.
  - b. Second calendar year is the calendar year immediately following the first calendar year.
  - c. Whether an animal belongs to a person who is a member of one of the Texas Regional clubs or not, showing in any Mule show will count as one year.
  - d. Exceptions to the time limit rule involving extreme circumstances would be heard by the Texas Rule Book Committee-Hearing Committee.
5. An animal that has been shown two years as Green, then changes

ownership, may not be shown again in Green.

6. A Green Performance Division is recommended but not required in every Texas sanctioned show. However, if any Green Performance classes are offered, just one Green class cannot be offered. If Green is offered, there must be a minimum of 3 Green Performance classes in each sanctioned show and some type of recognition for the overall Green Performance Division winner. Suggested classes would be: Pleasure, Trail, Mulemanship/Donkeymanship, or Reining, however, other Performance classes could be used.

7. An animal being shown as Green in Performance classes which advances to a non-Green Performance "point" class in a show which offers Green classes will forfeit its Green status effective the NEXT Texas sanctioned show. HOWEVER, a Green animal CAN BE SHOWN in non-Green Performance classes, using Green equipment rules, in a show which DOES NOT OFFER GREEN CLASSES, and still maintain it's Green status.

See 1.8 K.2. for OPEN class rules and green eligibility.

a. A class which is deemed a "non-point" class by show management and not included in the point system for a "Performance" division High Point or championship award for the show will be excluded from this ruling.

b. The riding of a Green animal in a Novice class does count toward the animal's two year Green Status.

8. An animal being shown as Green in the Performance division may be shown in non-Green classes in any other division (i.e. Showmanship, English, Driving, Gymkhana, Packing, Cow Classes) or category (Novice, Youth, Open).

a. Green animals will not be excluded from competing in more than one awards category.

9. A mule being shown in Green Western Performance classes must be shown with an approved Western Performance snaffle or bosal and be ridden with two hands.

10. Green mules shown in non-Green classes may be ridden two-handed with a snaffle or bosal. (See Rule 7 above.)

11. Problems or protests regarding animals entered as Green MUST BE PRESENTED TO THE SANCTIONING CLUB'S HEARING COMMITTEE DURING THE SHOW IN QUESTION AND PRIOR TO THE AWARD

PRESENTATIONS. Actual protests must be accompanied by the normal \$50.00 check which will not be returned if the protest is overruled. Each Club is encouraged to retain accurate and accessible records regarding Green animals.

- a. Proof obtained by a protestor after the show can be provided at the beginning of the next show to prevent further entry in Green classes, if necessary.
  - b. Special consideration may be given in a case where a new member, who is unfamiliar with the rules, has entered and competed on an animal in both Green and Adult classes but actually prefers to continue in Green. Each Club must arbitrate problems such as this on an individual basis, but it is noted that a onetime exception to Rule 1.8 J. 7 would be reasonable.
12. Donkeys may be ridden two-handed with any approved bit, either snaffle/bosal or curb.
  13. Animals may not be shown with any type of training equipment.
  14. It is NOT RECOMMENDED that the Green Western Pleasure class be limited to Walk/Trot, but if show management decides to make that limitation, it must be stated on the show flyer and all classes in the Green Division must be limited likewise, (i.e. The Trail Class must not require a lope.)
  15. A Youth/Sub-Youth may show a Green animal in Youth/Sub-Youth classes.
  16. A Novice may show a Green animal in Novice classes.
  17. Although it is NOT recommended to show donkeys and mules in the same class, they may be combined for Green classes if designated as such on the show flyer.

K. OPEN - ANIMALS 36.01 AND OVER (See Miniature Section for Rules Governing Open Adult Miniature Donkeys and Mules.)

1. A performance class in which both Youth and Adult exhibitors may participate.
2. Open classes will be open to all exhibitors; Adult, Novice, Green, and Youth. Green to follow rules for green equipment and classes entered will count towards the two year time limit. In all open classes a youth may not show a jack.

L. WESTERN PERFORMANCE CLASSES

1. Any judged riding class requiring western equipment and attire.

M. AGE OF ANIMAL

1. The age of an animal shall be computed on the basis of a calendar

year starting January 1 of the year foaled. It is a weanling during the calendar year in which foaled and a yearling during the first calendar year following its foaling date, regardless of the time of the year foaled.

**All subsequent rules governing Miniature Donkeys (Donkeys 36” and under) will be specifically addressed in the Miniature Donkey and Mules Rules Section at the back of this book. Sections II-XII are designed as Large Animals Division (Donkeys and Mules 36.01” and over).**

## **N. Amateur**

1. Amateur is any rider nineteen years old and older on January 1 of the calendar year of the show who is no longer eligible to show in Youth classes, and who has not shown, judged, trained or assisted in training a mule, donkey, or horse for remuneration, either directly or indirectly, nor received compensation for instructing another person in riding, driving, training or showing a mule, donkey or horse in competition for the previous five calendar years.

### **2. Amateur Guidelines**

A. Amateur cards will be issued only upon application and approval of the applicant. The application shall be truthful in each and every detail. Amateur cards issued by NASMA, IMAD, AQHA, APHA, SDMS, GCDMA, Palomino Horse will be accepted. Other breed amateur cards may be accepted with approval from the sanctioning club as determined at time of entry by the sanctioning club. Copies of Amateur cards or an application must be included with entry. Applications will be issued by the sanctioning club. No exhibitor may show in any approved Amateur event without possessing a current Amateur card.

B. Application shall verify that: the applicant has not shown, trained or assisted in training a horse/mule/donkey for five years previous to application for Amateur membership.

3. Amateur Eligibility: The application for Amateur card must be true and correct in each detail. Amateur applicants maintain eligibility when he or she meets and maintains the following requirements:

A. Is 19 years of age on or after January 1 of the year of application and is no longer eligible to compete in Youth classes.

B. Has not shown, judged, trained or assisted in training a horse/mule/donkey for remuneration, defined as monetary, either directly or indirectly.

C. Has not received remuneration for instructing another person

in riding, driving, training or showing a horse/mule/donkey for five calendar years previous to application for Amateur card.

D. Does not hold credentials of horse/mule/donkey show judge, any other equine organization.

E. Cannot hold membership accreditation as a professional for those events which are the same events or classes the individual competes or desires to compete in Amateur competition. (i.e. A person who competes in PRCA roping event may not compete in Amateur Calf roping, etc.)

F. Has not, nor during the period of Amateur status, cannot show a horse/mule/donkey for which the person's spouse has previously received remuneration for training during the 12 month period preceding the show of the horse/mule/donkey by the Amateur in Amateur or open competition.

G. Every person competing in an Amateur class must possess a current individual Amateur card. Show management should inspect this card at any show entered by requiring a copy of the card or an application to be sent in with the entries or presented at time entry is made.

H. Upon revocation of Amateur membership because of ineligibility, all earned points from time of violation of eligibility shall be revoked.

I. Should the Amateur be found in violation of the amateur rules the penalties shall be as follows:

(1) First Violation: suspension from Amateur classes for a period of one year from time of violation:

(2) Second Violation: a suspension from Amateur classes for a period of two years from the time of violation.

(3) Third Violation: a suspension of five years from time of violation

#### 4. Amateur Committee:

a. The Amateur Committee is considered as a Standing Committee and follows these guidelines.

b. As a Standing Committee, it will consist of not less than three members, and not more than one can be an Amateur card holder. Each member will be appointed by the President for not less than one year and not more than three years.

c. The Amateur Committee from the sanctioning club will evaluate all applications and be responsible for issuing cards.

d. The amateur committee will preside over any formal hearing regarding a member's eligibility or discipline following the procedures set up for protecting the due process of all involved in the protest.

e. Decisions of these hearings must be completed and announced within one month. Extensions of this time frame may be granted based on written request from the committee or the individual member about whom the hearing is called.

## **O. Beginner Adult**

1. Open to an inexperienced adult rider not entered in another division.
2. Beginner class is limited to one calendar year of participation, and should be offered, when possible, to allow some special classes to those who consider themselves beginner riders, in order to only compete with their peers.
3. Beginner classes will be conducted as walk / trot only.
4. In shows offering **Beginner** classes, a person must choose between a Beginner or Adult of the same type. In a show not offering **Beginner** classes a person may enter any class he/she desires without affecting his/her ability to return to Beginner classes when offered.
5. Should any problems arise at a show regarding entries in Beginner classes, those problems should be handled just as in Rule 1.8 J. 11.
6. A Beginner may ride a Green animal and use Green equipment in Beginners designated classes. (This will not affect the animal's "Green" status but being shown in Beginner classes will count toward the animal's two-year limitation.)
7. Although it is NOT recommended to show donkeys and mules in the same class, they may be combined for Beginner classes if designated as such on the show flyer.
8. Suggested classes: Showmanship, Western Pleasure or Walk / Trot, Trail.
9. Points for Beginner Divisions / High Point will be accumulated on a one rider / one animal combination, and may be of lesser value than the normal High Point awards.
10. Any entry in a lope class will disqualify the participant from future Beginner classes.

## **P. Select Division**

1. Select is any rider fifty-five years old and older on January 1 of the calendar year of the show who qualifies by age, and who has not shown, judged, trained or assisted in training a mule, donkey, or horse for remuneration, either directly or indirectly, nor received compensation for instructing another person in riding, driving, training or showing a mule, donkey or horse in competition for the previous five calendar years.
2. Select class should be offered, when possible, to provide riders 55 and over some special classes in which to compete only with their

peers.

3. Select classes may be conducted as walk/ trot only, to be stated on the show flier.
4. In shows offering Select classes, a person must choose between a Select or Adult class of the same type. (ie. may not enter both Adult Trail and Select Trail). In shows not offering Select classes, a person may enter any classes they desire without affecting their ability to return to Select classes when offered.
5. Should any problems arise at a show regarding entries in Select classes, those problems should be handled just as in Rule 1.8 J. 11.
6. A Select participant may ride a Green animal in Select designated classes. (This will not affect the animal's "Green" status, but being shown in Select classes will count toward the animal's two-year limitation.) See equipment rules
7. Although it is NOT recommended to show donkeys and mules in the same class, they may be combined for Select classes if designated as such on the show flyer.
8. Suggested classes: Showmanship, Western Pleasure, Mulemanship /Donkeymanship, and Trail.
9. Points for Select Divisions will be accumulated on a one rider / one animal combination.

## **II. ATTIRE**

### **2.1 Halter, Western Performance, Speed Events and Cattle Classes**

- A. Clothing: When entering the arena, persons shall be attired in long sleeved shirt or blouse with collar, long pants, boots and hat.
- B. Protective head gear with harness would also be allowed as optional equipment for all classes.

### **2.2 English Performance Classes**

- A. In all English Hunter and Jumping classes, exhibitors and judges should bear in mind that, at all times, entries are being judged on ability rather than on personal attire. However, riders should wear hunting attire consisting of jacket, breeches or jodhpurs, high English boots or Jodhpur shoes. Dark hunting cap or hard derby is mandatory. Stock, tie or choker is required, spurs of the unrowelled type, crops or bats are optional. Hair must be neat and contained (as

in a braid or net).

- B. In all English Pleasure classes, attire should be informal dress consisting of conservative solid colored jackets with matching jodhpurs and derby or soft hat. (Note that this is really a Saddle Seat type class - NO HUNT ATTIRE. Use Hunter Under Saddle for hunt attire. Care should be taken to choose the correct type of class {judging is very similar - see Rules 8.2 and 8.5} for the majority of exhibitors in the area.)
- C. Judge must penalize contestants who do not conform.
- D. It is mandatory that all youth wear a hard hat with harness in all over fence classes.
- E. It is mandatory that all exhibitors wear a hard hat in all over fence classes and they are encouraged to wear hard hats when schooling over fences.

## **2.3 Driving Classes**

- A. Western or English attire, as described above, may be worn.
- B. Any period costume may be worn that is related to and appropriate for the vehicle being driven. Costume must have long sleeves. If female exhibitor is attired in a dress, a lap robe is required.
- C. Gloves are recommended for all driving classes.

## **2.4 Exceptional Attire**

- A. If weather conditions require, exhibitors may wear pertinent or inclement weather apparel over the normal class attire.
- B. During severe wind conditions, show management may make the decision to revoke the required western hat rule.
- C. During extreme heat, the decision to remove coats in English classes will be made by the judge.
- D. See the rules for specific classes for any other exceptions to the general attire rules.

## **III. EQUIPMENT**

### **3.1 Halter Classes**

A. Blind bridles are not allowed, however, an open headstall with bit or some type of halter/bit combination will be allowed.

### **3.2 Western Performance Classes**

A. In all judged western classes, animals will be shown in a Western, McClellan, or Australian Stock saddle. Silver equipment will not count over a good working outfit. A bosal or a curb, snaffle, half-breed or spade bit is permissible.

1. A bosal or snaffle with two hands is permissible in green classes or any other western performance classes only if being used on green mules.

a. A non-green mule may NOT be ridden with a snaffle.

b. A non-green donkey may be ridden with a snaffle two-handed.

#### **B. Definitions**

1. Bosal (hackamore) - a flexible, braided rawhide or leather or rope bosal, the core of which may be either rawhide or flexible cable. Absolutely no rigid material will be permitted under the jaws, regardless of how padded or covered. (Not a "mechanical" hackamore.)

2. Snaffle bit - a conventional O-ring, egg-butt or D-ring with a ring no larger than 4". The mouthpiece should be round, smooth, unwrapped metal; it may be inlaid, but smooth or latex-wrapped. The bars must be a minimum of 5/16" in diameter, measured one inch in from cheek with a gradual decrease to center of the snaffle. The mouthpiece may be two or three pieces. If it is a three-piece, a connecting ring of 1 1/4" or less in diameter, or a connecting flat bar of 3/8" to 3/4" (measured top to bottom, with a maximum length of 2"), which lies flat in the animal's mouth are acceptable. May have leather strap or legal curb chain to prevent pulling through the mouth.

3. Bit - refers to the use of a curb bit that has a solid or broken mouthpiece, has shanks and acts with leverage. All curb bits must be free of mechanical device and should be considered a standard Western bit. A description of a legal, standard Western bit includes:

a. 8 1/2" maximum length shank to be measured as indicated in the

diagram. Shanks may be fixed or loose.

- b. With regard to mouthpieces, bars must be round, smooth and unwrapped metal of 5/16" to 3/4" in diameter, measured 1" from the cheek. They may be inlaid, but must be smooth or latex wrapped. Nothing may protrude below the mouthpiece (bar), such as extensions or prongs on solid mouthpieces. The mouthpiece may be two or three pieces. A three-piece, connecting ring of 1 1/4" or less in diameter, or a connecting flat bar of 3/8" to 3/4" (measured top to bottom with a maximum length of 2"), which lies flat in the animal's mouth is acceptable.
- c. The port must be no higher than 3 1/2" maximum, with rollers and covers acceptable. Broken mouthpieces, half-breeds and spades are standard.
- d. Slip or gag bits, and donut and flat polo mouthpieces are not acceptable.

4. Chain curbs or chains - When a curb bit is used, a curb strap or curb chain is required.

- a. Curb chains must meet the approval of the judge, must be at least 1/2" wide, and must lie flat against the jaw of the animal. (If double chain, the total width must equal 1/2".)
- b. A broken strap or chain is not necessarily cause for disqualification.

5. Romal - An extension of braided material or leather attached to closed reins. This extension is allowed to be carried in the free hand with a 16" spacing between the rein hand and the free hand holding the romal. It shall not be used forward of the cinch or used to signal or cue the animal in any way. Any infraction of this rule shall be penalized severely by the judge. Hands shall be around the reins. No finger between the reins is permitted.

6. Split Reins - Only one hand to be used (optional with donkeys). Hand is to be around reins, index finger only between reins. Stack to be carried on same side as hand being used to hold reins. Rider may not change hands except to work obstacles. (For Sub-Youth safety, split reins should be "joined" in some unobtrusive manner.)

## 7. Optional Equipment

- a. Rope or riata: If used, the rope or riata must be coiled and attached to the saddle.
- b. Hobbles attached to saddle.
- c. Tapaderos, except in working cow mule where they are not allowed.

- d. Protective boots except in western pleasure, trail and halter, where they are not allowed.
  - e. Leg wraps except in western pleasure, trail, showmanship at halter and donkey/mulemanship, where they are not allowed.
  - f. Spurs - not to be used forward of the cinch.
  - g. Cruppers
8. Prohibited Equipment
- a. Wire chin straps, regardless of how padded or covered.
  - b. Any chin strap narrower than one-half inch.
  - c. Martingales, cavesson nosebands and tie-downs.
9. In a judged western class, spurs, romals and rein ends may not be used forward of the cinch to cue an animal. Such use will be penalized by the judge.
10. Fall of animal or rider will result in disqualification.

### **3.3 English Classes**

- A. Animals must be shown in appropriate English tack for the class. Judge's discretion to penalize an animal with non-conventional types of bits or equipment.
- B. Bits & Bridles - In all English classes and jumping, an English snaffle (no shank), kimberwick, pelham and/or full bridle (with two reins), all with cavesson nosebands and plain leather brow bands, must be used. In reference to mouthpieces, nothing may protrude below the mouthpiece (bar). Solid and broken mouthpieces may have a port no higher than 1 1/2". On broken mouthpieces only, connecting rings of 1 1/4" or less in diameter or connecting flat bar of 3/8" to 3/4" (measured top to bottom with a maximum length of 2") and which lie flat in the animal's mouth are acceptable. All mouthpieces must be a minimum of 5/16" in diameter -snaffles to be measured 1" in from the cheek or ring. Smooth round, slow twist, corkscrew, single twisted wire, double twisted wire mouthpieces and straight bar or solid mouthpieces with a maximum of 1 1/2" high ports are allowed. Bits of any style (pelham, snaffle, kimberwick) featuring mouthpieces with cathedrals, donuts, prongs, edges or rough, sharp material shall be cause for elimination. If a curb bit is used, the chain must be at least 1/2" in width and be flat against the jaw of the animal.

1. Hunter Brow Bands - plain leather
  2. English Pleasure (Saddle Seat) Brow Bands - may be leather or a patent material in a conservative color which is complimentary to rider's outfit.
- C. Saddles & Pads
1. Hunter Classes - Saddles must be of black and/or brown leather or synthetic of traditional hunting or forward seat type; knee insert on the skirt is optional. Saddle pads should be white or natural color to fit size and shape of saddle.
  2. English Pleasure (Saddle Seat) - must use a show, cutback or park saddle and full bridle (double reins on weymouth or pelham bit, or can use snaffle with one rein.) Saddle pads are optional.
  3. Donkey English Classes-Donkeys may be ridden in any style English saddle.
- D. Fall of animal or rider will result in disqualification.

This Page Intentionally Left Blank

# ACCEPTABLE CHAIN CURB STRAPS



## WESTERN BITS

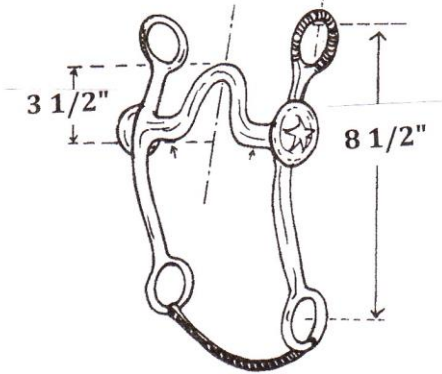

LEGAL BIT

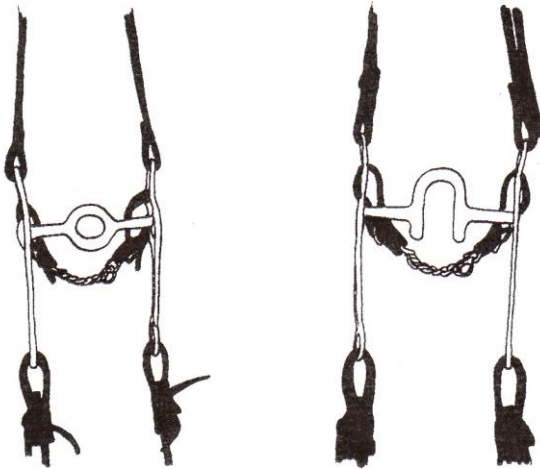

DONUT BIT

ILLEGAL BITS

PRONG BIT

## Acceptable English Bits For All Ages



Slow Twist

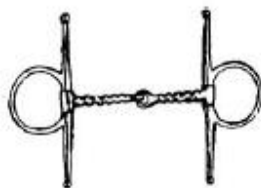

Corkscrew

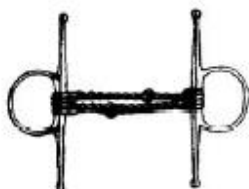

Double Twisted Wire

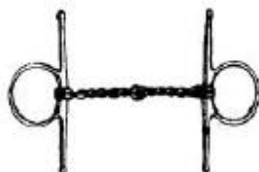

Single Twisted Wire

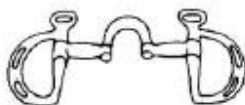

Correction Bit



Saffle Bit with  
Connecting Flat Bar

## Unacceptable English Bits



Excessive Port

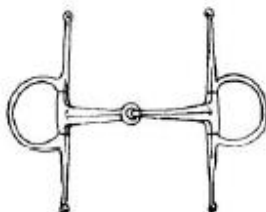

Triangular Mouth

## D. Other Equipment

### 1. Optional Equipment

- a. Spurs of the unrowelled type
- b. Crops or bats
- c. Gloves
- d. English breast plate (except in English Pleasure where they are not allowed)
- e. Braiding of mane and/or tail in hunt style
- f. Standing or running martingales in working hunter, jumping and equitation over fences only
- g. Boots in jumping only
- h. Leg wraps in jumping only
- i. Cruppers

### 2. Prohibited equipment

- a. Draw reins
- b. Rowelled spurs
- c. Standing or running martingales except in working hunter, jumping and equipment over fences
- d. Boots of any description except in jumping, and outdoors during inclement weather in working hunter and equitation over fences
- e. Leg wraps, figure 8 or flash cavessons except in jumping
- f. English breast plates in English Pleasure

## **3.4 Speed Events and Cattle Classes**

A. In speed events and cattle classes, western-type equipment must be used. Use of a hackamore (including mechanical hackamores) or other types of bits is the optional choice of the contestant. However, the judge may prohibit the use of bits or equipment he may consider severe (if questionable equipment, ask the Ring steward to discuss with judge before the start of show.)

### 1. Strictly Prohibited Equipment (also see 3.7 for illegal bits)

- a. Jerk Lines
- b. Tack Collars
- c. Wire Bats

B. In a timed event, bats, quirts or spurs are permitted, but may not be used forward of the cinch.

C. Short over-under rope attached to saddle may be used.

D. Any time an animal's mouth is tied or fastened in any fashion, the animal may be disqualified.

### **3.5 Driving Classes**

A. Driving equipment to be used shall include suitable cart or wagon, collar or breast collar harness, including breeching or thimbles and standard bridle with snaffle or curb bit. If a curb bit is used, the chain must meet with the judge's approval. Such a chain must be at least 1/2" in width and lie flat against the jaw of the animal. Whip must be carried in the cart at all times. The overall length of the whip for a single donkey should be long enough to reach its shoulder. Driver shall be penalized for excessive use of the whip. Lap robes must be used by ladies with dresses and are optional equipment any other time.

#### 1. Definitions

- a. Snaffle - a bit without shanks or curb chain (may have leather strap to prevent pulling through the mouth) which works on direct contact; may have broken or straight mouth piece. Single or double-wire bits are legal.
- b. Curb - a bit with shanks which works by leverage. Legal, flat curb chains or leather straps allowed (Rule 3.2 B 4).

#### 2. Optional Equipment

- a. Check reins
- b. Blinders
- c. Martingales
- d. Cavesson nosebands
- e. Gloves

#### 3. Prohibited Equipment (also see 3.7 for illegal bits)

- a. Wire curbs, regardless of how padded or covered
- b. Running W
- c. Fifth Wheel Brake (aka Donkey Brake)

### **3.6 General Equipment Rule**

A. Ornate silver equipment or any other fancy equipment will not count over clean and workable equipment. The only exception to this rule will be in the Parade Hitch Class.

### **3.7 Illegal Bits for All Classes**

- A. Bicycle chain bits
- B. Hooks inside or outside
- C. Snaffle with high port (3 1/2" maximum)
- D. Curb with shanks longer than 8 1/2"
- E. Welding to or changing bit surface from smooth to bumpy or sharp
- F. Wire wrapped bit
- G. No blood will be tolerated inside or outside the mouth

## **IV. CLASS RULES – HALTER**

### **4.1 Halter Classes**

- A. Animals in halter classes are to be judged strictly on conformation which includes fitting and condition.
- B. No artificial aids for control (such as canes, show sticks, or whips) or for attention (such as cigarette lighters) may be used during halter classes for either donkeys or mules. (Also 3.1)
- C. A donkey or mule may be exhibited in only one point earning halter class.
- D. If offered, Foal and Yearling classes will count as High Point earning classes.
- E. Halter classes are determined under the following guidelines but can be combined or changed to suit entries.

1. Foals - Donkey or mule foaled in calendar year of show. If entry numbers warrant then there should be separate classes for each.
  2. Yearlings - Donkey or mule foaled in calendar year preceding show year. If entry numbers warrant then there should be separate classes for each.
  3. Donkeys - 2 years and older may be shown under the following height and/or sex classifications (measured at the withers):
    - a. Miniature up to 36 (see mini section for recommended class list)
    - b. Standard 36.01" to 48.00"
    - c. Large Standard
 

Jennets	48.01" to 54.00"
Jacks	48.01" to 56.00"
Geldings	48.01" to 56.00"
    - d. Mammoth (Jackstock)
 

Jennets	54.01 "and up
Jacks	56.01" and over
Geldings	56.01" and over
    - e. Geldings of all sizes
  4. Mules - 2 years and older may be shown under the following heights and/or sex classifications (measured at the withers):
    - a. Mules up to 48"
    - b. Mules 48.01" to 52.00"
    - c. Mules 52.01" to 58.00"
    - d. Saddle Mules 58.01"& over
    - e. Draft Mules 58.01" & over
- (Foals and yearlings may enter this division if no foal or yearling classes are offered at a show and should enter the appropriate class for their estimated mature height.)
- F. Jacks 12 months of age and over must be shown with a chain lead over, or under, and/or through the mouth, or with a bit type halter. If animal warrants, two handlers may be used but both handlers will remain at the head of the jack. Each handler must have a chain lead. There is no point deduction for two handlers. The Ring steward may excuse any animals that do not have proper lead lines.
  - G. Halter classes may be split in the case of extremely large classes or if other conditions warrant, depending on the opinion of the judge and/or Ring steward. Donkey classes may be split into Youth (animals

under 4 years) and Senior (animals over 4 years) divisions. Mule classes may be split as described above or may be split into divisions of Molly Mules and Horse Mules.

H. In situations where both donkey and mule judges are used and as other situations may warrant, halter classes may be judged simultaneously. If only one handler is available to show his animals, then one of the classes may be held up until the exhibitor can leave one class to go to the other class. Exhibitor must notify the gatekeeper, prior to class closing, that he has animals in two classes at the same time.

## **4.2 Additional Halter Classes**

A. Brood stock - Jennets and mares with foals or yearlings. Offspring to be no more than 24 months old. Separate classes for jennets and mares. To be judged 40% on dam and 60% on offspring. Entries are to be entered under Dam's name. Not a point class.

B. Get of Sire - Two animals that are sired by one jack. The pair may be donkeys, mules or one of each and are shown at halter as one entry. Entered under the name of the jack (jack does not need to be present). Judged on conformation this includes fitting and conditioning. Not a point class.

C. Produce of Dam - Two produce, (two only per entry) can be of either type or sex with no age limit. Entered under the name of the dam, (dam need not be present). Judged on conformation, which includes fitting and conditioning. Not a point class.

D. Matched Pairs - Open to donkeys and mules. Judged 50% conformation and equal qualities and 50% suitability to perform as a matched team. Donkeys and mules may be split in the arena and be judged separately. May count for points for a Team Division only.

E. Model/Reserve Model Halter - Donkeys and mules to be judged and awarded separately. Object of this class is to select the animal in the show that comes the nearest to ideal animal.

Class procedure:

1. The first place and second place animals in all point earning halter

classes will be lined up with the second place animal directly behind the first place animal; then the front row will be judged for Model.

2. The second place animal directly behind the animal picked for Model will then take its place in the front row to be judged for Reserve Model.

## **V. CLASS RULES – SHOWMANSHIP**

### **5.1 Showmanship Classes**

- A. Showmanship is a performance class, not a halter class.
- B. **Patterns may be posted on the website prior to the start of the show, or at the venue no less than 1 hour prior to the class itself.**
- C. Class divisions:
  1. Youth - donkeys and mules to be judged separately.
  2. Sub-Youth - may be mixture of donkeys and mules.
  3. Adults - it is recommended that donkeys and mules be judged separately, but they may be combined if noted on the show flyer.
- D. Youth may not show a jack. See miniature donkey **and mule** section related to youth exhibiting miniature donkeys.
- E. Only exhibitor to be judged. The animal is merely a prop to show the ability of the exhibitor. This class shall be judged strictly on the contestants' ability to fit and show in a halter class.
  1. Appearance of Animal 40 points
    - a. Condition and Thriftiness (15 Points)
    - b. Grooming (15 Points)
      - (1) Hair coat clean, well brushed.
      - (2) Mane, tail, foretop and wither tufts free of tangles and clean. It is prohibited to use any ornaments on the aforementioned. Manes, tails foretops and wither tufts may be English braided or western braided if the exhibitor so desires or the schedule of classes dictates due to time.

(3) Hoofs trimmed properly. If shod, shoes must fit properly and clinches should be neat.

c. Trimming (5 Points)

(1) Manes and foretops may be trimmed or not as desired by owner.

(2) Inside of ears may be clipped, or just the outer edges clipped leaving protection inside the ear.

(3) Long hair on jaw, legs and pasterns should be clipped.

d. Tack (5 Points)

(1) Tack should be neat, clean and in good repair.

2. Appearance of Exhibitor 10 Points

a. Clothes and person - neat and clean,

b. Suitable western clothes. (See Section 2.3)

3. Showing Animal in Arena 50 Points

a. Leading\* (15 Points)

(1) Enter arena leading animal at an alert walk in a counter clockwise direction by judge. Walk on animal's left side, holding lead shank in right hand, near halter. The remaining portion of lead is held neatly and safely in left hand. A tightly coiled or rolled lead shank will be considered a fault in showmanship. Animal should lead readily at a walk or trot.

(2) After judge has lined up the class in front of spectators, he will call on each exhibitor to move his animal individually. When moving the animal, be sure that the judge gets a clear, unobstructed view of the animal's action. Allow the animal sufficient lead so that he can move freely and in a straight line. Lead the animal from his left side the required distance, stop and turn to the right around the animal.

(3) It is mandatory that the judge post the pattern he will ask for at least one hour prior to the commencing of the class; however, if the judge chooses to bring back exhibitors for consideration of final placing, the

finals pattern need not be posted.

b. Posing (15 Points)

- (1) When posing your animal, stand toward the front facing the animal, but not directly in front of the animal and always in a position where you can keep your eye on the judge.
- (2) Pose the animal with his feet squarely under him. Do most of the showing with the lead strap. Never kick animal's leg into position.
- (3) Do not crowd the exhibitor next to you when in a side by side position. Do not crowd exhibitor in front when lined up head to tail.
- (4) When judge is observing other animals, let your animal stand if posed reasonably well.

\*(Update: In addition to the working description provided in 3.a.(1) and (2), the judge may alternately require exhibitors to begin their pattern from the gate individually.)

- (5) Be natural; theatrical over-showing, undue fussing and maneuvering are highly objectionable, as is running in a "squat" position when trotting your animal.

THE QUARTER METHOD: Suggested Guidelines of Movement - The following guidelines are meant to serve as an illustration of movement around the animal while showing in Showmanship at Halter and are for the exhibitor's information: Imaginary lines bisect the animal into four equal parts as seen in Figure A. (Note: The quadrants will be numbered I, II, III, IV for ease of identification.) One line runs across the animal just behind the withers. The other imaginary line runs from head to tail. When the judge is in I the handler should be in IV. As the judge moves to II, handler should move to I. When the judge moves to III, the handler moves to IV. As the judge moves up the animal to IV, the handler returns once more to I. This method is based on safety as the handler can keep the animal's hindquarters from swinging toward the judge should the animal become fractious.

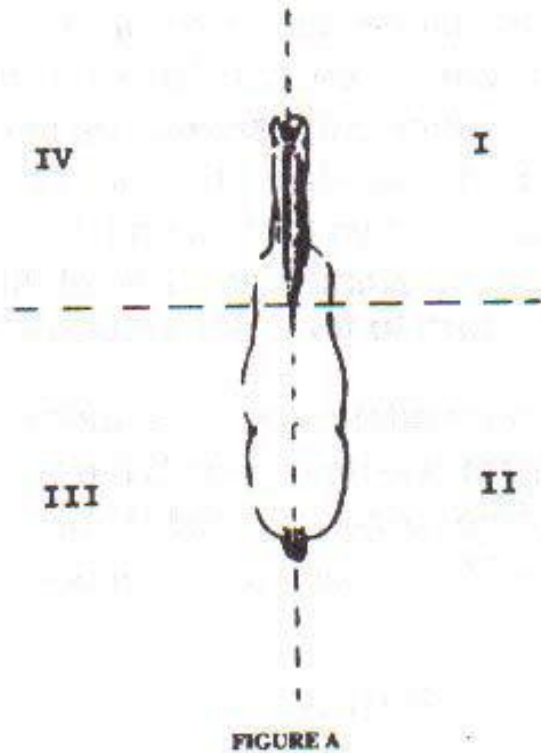

#### Poise, Alertness and Merits (20 Points)

- (1) Keep alert and be aware of the position of the judge at all times. Don't be distracted by persons or things outside the ring.
- (2) Show animal at all times, not yourself.
- (3) Respond quickly to requests from judge and officials.
- (4) Be courteous and sportsmanlike at all times.
- (5) Recognize quickly and correct faults of your animal.
- (6) Keep showing until the entire class has been placed and has been excused from the ring.

# **VI. CLASS RULES – DRIVING**

## **6.1 General Driving Rules**

A. See Section 2.3 for Attire Rules

B. See Section 3.5 for Equipment Rules

C. **AUTOMATIC DISQUALIFICATION:** Anywhere on the show grounds, the failure to have a header in place when driver is not in vehicle, or the removal of a bridle while the animal is still between the shafts will result in automatic and **IMMEDIATE** disqualification

1. Driver may exit vehicle and head his own animal.
2. Do not tie hitched animals and leave unattended.

D. Gaits

1. Walk - A natural, flat foot, four beat gait. Loss of forward rhythmic movement shall be penalized.
2. Trot (Park Gait) - A forward, free flowing, square trot with impulsion. Loss of forward, rhythmic movement or jogging shall be penalized.
3. Extended Trot (Road Gait) - A trot showing a definite lengthening of stride, with a noticeable difference in speed. Short, quick, animated strides and/or excessive speed shall be penalized.

E. **Cantering:** Cantering more than 4 strides in any driving class is an automatic disqualification unless stated otherwise in specific class rules.

F. Reversals

1. In all driving classes, reversals must be at a walk and will be made on the diagonal at the direction of the Ring steward only. The correct way to reverse is shown in the drawing below.

## Correct Way to Reverse

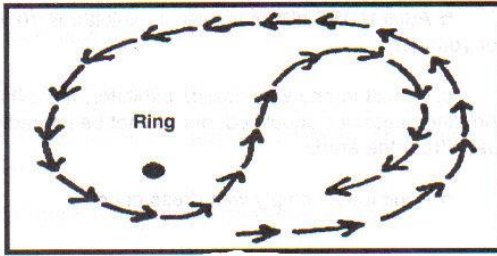

- G. Course Distances: In pattern classes where cones are used, the minimum distance should be based on the widest permanent part of the vehicle (usually rear axle but could be tree width) plus 16 inches (ADS rule). (FYI: 1 meter = 40"; 4 meters = -13'; 5 meters = -17")
- H. Should a breakdown occur during the competition, the exhibitor shall have 5 minutes to make necessary repairs, after which time exhibitor will be excused from the show ring. Should a breakdown occur on the way to the arena, the exhibitor shall have 5 minutes to make repairs, after which, if repairs have not been made, then exhibitor is excused from entry.
- I. In all classes except for Parade Hitch, fancy equipment not to count over neat, suitable working outfit.
- J. Fall of animal or driver will result in disqualification.
- K. No Headers allowed, except for emergency situations.

## 6.2 Single Hitch Driving

- A. There will be separate classes for donkeys and mules (although not recommended, maybe combined in Novice and Green if noted on show flyer).
- B. Suitable wheeled vehicle to be used.
- C. To be shown at a walk, trot and extended trot both ways of the show ring.
- D. All entries will be asked to back.
- E. Judged 90% on manners and way of going and 10% on appointments

F. Divisions: (for Donkeys less than 36" refer to Miniature section)

1. Adult
2. Youth
  - a. Adult MAY ride in vehicle with exhibitor 11 years and older.
  - b. Adult MUST ride in vehicle if exhibitor is 10 years old or younger.
  - c. If adult in any way assists exhibitor, the exhibitor will be automatically disqualified, but will not be immediately excused from the arena.
  - d. Adult must comply with dress code.

G. In shows or events in areas with large numbers of driving contestants driving several different types of vehicles, this class could be divided and designated as:

1. Antique or Classic type vehicle, 2 or 4 wheels (pneumatic tires may be permitted)
2. Farm Class Vehicle, 2 or 4 wheels, open to rubber or iron tired, home built, training vehicle or farm type equipment

### **6.3 Single Hitch Obstacle Driving**

- A. There will be separate classes for donkeys and mules (although not recommended, maybe combined in Novice and Green if noted on show flyer).
- B. Animal will be judged on the ease of maneuvering between and around obstacles including backing.
- C. Breaking the pattern or allowing animal to canter will be an automatic disqualification.
- D. Judged 90% on manners and way of going, 10% on appointments.
- E. Not a timed event.
- F. Three refusals at any one obstacle, exhibitor must proceed to next obstacle.
- G. Pattern will be posted no less than 1 hour prior to the class itself.

H. Refer to end of driving class rule section for a list of suggested obstacles for driving, but note that obstacles are not limited to that list.

### 6.4 Single Hitch Timed Driving

- A. There will be separate classes for donkeys and mules (although not recommended, may be combined in Novice and Green if noted on show flyer).
- B. Breaking the pattern or allowing animal to canter will be an automatic disqualification.
- C. Travel may be in either direction.
- D. There will be a 5 second penalty for knocking over any pylon.
- E. Pattern with dimensions shown in drawing.

#### Timed Driving Pattern

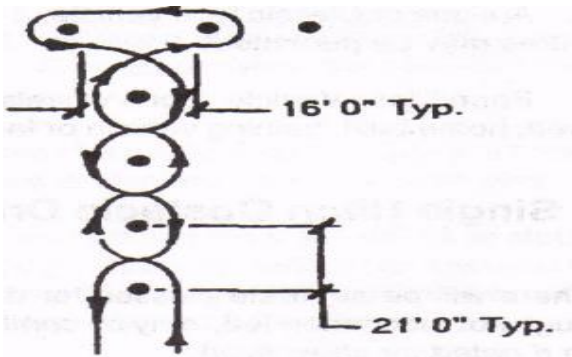

### 6.5 Multiple Hitch Driving

- A. Two or more donkeys or mules in a team, hitched to any suitable wheeled vehicle. (It is not recommended for donkeys and mules to be shown together, but they may be combined if stated on show flyer.)
- B. Teams will work at a walk and trot both ways of the show ring.
- C. Teams will be asked to "figure 8", back straight and gee-haw in place.

- D. Because not all vehicles are equipped with brakes, usage of brakes may be penalized at the discretion of the judge if they are used to gain an advantage while performing required maneuvers.
- E. Judged 75% on manners and way of going, 20% on matched suitability and 5% on appointments.
- F. Youth exhibitors excluded.
- G. In shows or events in areas with large numbers of driving contestants driving several different types of vehicles, this class could be divided and designated as:
  - 1. Antique or Classic type vehicle, 2 or 4 wheels (pneumatic tires may be permitted).
  - 2. Farm Class Vehicle, 2 or 4 wheels, open to rubber or iron tired, home built, training vehicle or farm type equipment

## **6.6 Multiple Hitch Obstacle Driving**

- A. Open to pairs only, donkeys or mules. (It is not recommended for donkeys and mules to be shown together, but they may be combined if stated on show flyer.)
- B. This class to test, in simulated situations, the working ability of each hitch which will include backing, maneuvering between and around obstacles and gee-haw ability.
- C. Breaking the pattern or allowing animals to canter will be an automatic disqualification.
- D. Not a timed event.
- E. Three refusals at any one obstacle, exhibitor must proceed to next obstacle.
- F. Pattern will be posted no more than 2 hours prior to the start of the show on the day of the class, and no less than 1 hour prior to the class itself.

- G. Judged 80% on performance over obstacles, 10% on animals' ability to work together and 10% on appointments.
- H. Youth exhibitors excluded.
- I. Refer to end of driving class rule section for a list of suggested obstacles for driving, but note that obstacles are not limited to that list.

## **6.7 Parade Class**

- A. May be open to single, double or multiple hitch, donkey or mule. (It is not recommended for donkeys and mules to be shown together, but they may be combined if stated on show flyer.)
- B. Will allow those with fancy parade turnout to show to their best advantage. Animals will be asked to walk and trot both ways of arena and "figure 8".
- C. Judge may ask for other tests at his own discretion.
- D. Drivers and passengers are requested to dress in appropriate attire which will add to the authentic appearance of the turnout.
- E. Judged 50% on manners and way of going and 50% on appointments
- F. Youth exhibitors excluded from driving.

## **6.8 Reinsmanship**

- A. Classes should be separate for donkeys and mules. (It is not recommended for donkeys and mules to be shown together, but they may be combined if stated on show flyer.)
- B. A pleasure driving class in which entries are judged primarily on the ability and skill of the driver.
- C. Driver judged on ability to maneuver a given course.
- D. Pattern will be posted no less than 1 hour prior to the class itself.
- E. Driver will be judged on the equipment and proper fit of harness to

vehicle.

F. It is suggested that driver drive with whip in hand.

G. Results as shown by the animal's performance are not to be considered more important than the method used by the driver in obtaining the results.

## **6.9 Gambler's Choice Driving**

A. May be open to donkeys or mules. (It is not recommended for donkeys and mules to be shown together, but they may be combined if stated on show flyer.)

B. May be singles or pairs but not mixed.

C. To be driven and timed over a course of unnumbered obstacles, each carrying a specific point value.

D. Each driver has the same amount of time to negotiate as many obstacles as possible. Each obstacle is assigned a point value according to its degree of difficulty and each driver tries to amass as high a score as possible within the time allowed. After passing through the starting line, the driver may drive through the obstacles, in any order, from any direction. Each obstacle may be driven twice but not in succession. If driven a third time, no points will be awarded. No obstacle may be driven again once it has been disturbed, with the exception of obstacles that are designed to be knocked down. If an animal should refuse or turn out at an obstacle without disturbing it, the driver may elect not to attempt it and may drive to another obstacle without penalty. The obstacle may be attempted later and if correctly driven, the appropriate points will be recorded. No points will be awarded for an incorrectly completed obstacle. If the obstacle is incorrectly driven but not disturbed, it may be attempted again. In this case, the succession rule does not apply.

E. A signal will sound at the end of the allowed time and the driver must then exit through the finish markers at which time the total time on the course will be recorded. If the signal sounds when the driver is committed to an obstacle, the driver may complete the obstacle and receive the appropriate points, then proceed through the finish markers for total time to be recorded. Whether or not the driver was committed to the last obstacle at the signal will be left to the discretion of the judge.

- F. Placings will be determined on a high score basis.
- G. Time will decide ties. If a tie occurs in both points and time, the winner will be decided by a drive-off.
- H. Cantering is not permitted, except in classes designated for Miniatures only.
  - 1. The first occurrence of cantering (4 strides or less) will result in a 5 point penalty; the second occurrence will result in disqualification.
  - 2. Cantering more than 4 strides will result in disqualification.
- I. Refer to end of driving class rule section for a list of suggested obstacles for driving, but note that obstacles are not limited to that list.

## **6.10 Versatility Ride and Drive**

- A. Classes will be separate for donkeys and mules.
- B. Animals will first be driven and judged as a pleasure driving class. Upon command, animals will go to the center of the arena for a tack change to continue the class to be judged as a pleasure riding class.
  - 1. Riding tack must be carried into the arena by the helper. It may NOT be carried in the vehicle during the class due to safety issues.
- C. Tack Change
  - 1. One helper may assist the driver/rider make a tack change. The helper will also be responsible for removing the vehicle with driving equipment from the arena as soon as the change has been made or as instructed before the class.
  - 2. It is not necessary to use a halter in the transition between driving bridle and riding bridle, but animal must be in continuous control. (Use of a rein, lead or some other available strap around the neck is appropriate.) Removal of ALL equipment, even for a moment, may result in disqualification.
- D. Failure to have a header in place or removal of bridle while the animal

is still between the shafts will result in automatic and immediate disqualification.

- E. The same person is to drive and ride the animal.
- F. Animal judged on ability as a combined riding and driving animal.
  - 1. Judged 60% under harness on manners, way of going and general turnout.
  - 2. Judged 40% under saddle on manners and way of going.
- G. Appropriate English or Western attire and equipment may be used.

## **6.11 Snigging**

- A. Classes will be separate for donkeys and mules. Classes can be established for singles or pairs and it is best that they be divided for different sized animals.
- B. Class consists of a log being pulled on the ground between a series of obstacles. (Sample patterns provided as a guide but any workable pattern combining the required skills of hooking, maneuvering obstacles and unhooking could be used.)
- C. Class will be held as a judged event.
- D. Course Set Up: Suggested distance between weaving cones is either 13 feet or 17 feet. Suggested distance between parallel obstacles (logs) is tree width plus 16 inches (ADS rule). (Note: It is important for management to provide single/double trees since different size "trees" will have advantage/disadvantage on a set course.) Adequate distance (minimum 13 feet) must be allowed for any end lines or side lines.
- E. Show management provides for large or standard mules or donkeys:
  - 1. Logs - proportionate in length and weight to the majority of animals to be shown in a particular class or division. For a mixed class - one average sized log as in "b" below can be used for all. The following are suggested size logs for various sized animals. (Diameter measurement taken at large end):

- a. Standard/Large Standard Donkeys/Mules under 14 hands - 8 foot 4 inch log, 4 inch diameter
  - b. Mammoth Donkeys/Saddle Mules over 14 hands - 8 foot log, 6 inch diameter
  - c. Draft Mules - 8 foot log, 8 inch diameter
2. Chain loop - each log will be wrapped with a piece of chain to make a loop not to exceed 24" to which a single tree (double tree) can be hooked. Chain extends from the sides of log (V shaped) in such a manner that the log will not turn.
3. Singletree (doubletree) with hooks and connector for log - per the following sizes. NOTE: See miniature section for miniature requirements.
- a. Single tree for all Donkey and Mule classes: 32"
  - b. Double tree for all sizes: 36"
- F. Hooking and unhooking is a part of the judging. The course must be set so the contestant can return the log to its original position, turned in the correct direction for the next contestant.
- G. No header or assistant will be allowed. ANY assistance results in disqualification.
- H. A penalty will be assessed each time an obstacle or course marker is either stepped on or over or disturbed in any way by the animal, the driver or the log. Tennis balls should be used on top of cones to indicate penalties.
- I. Failure to follow pattern is a disqualification.
- J. Drivers are allowed to encourage their animal forward with voice commands or slapping of reins (but not excessively). No whips or use of ends of reins allowed. Failure to follow this rule will result in disqualification.
- K. Driver may drive from either side, change sides as necessary or ride on top of log.
- L. Pairs Class - If two logs are used — they must be bound together in some manner to keep them from rolling.

## **6.12 Judged Log Dragging**

A. Class rules will be the same as for 6.11 Snigging with the following exceptions:

1. Rule 6.11 F would be deleted.
2. Rule 6.11 G would be deleted.

B. It should be clearly noted that this class does not represent snigging since snigging can only be represented by the inclusion of the hooking/unhooking process and the test of ability to return the log to its original position.



## **6.13 Suggested Obstacles for Single and Multiple Hitch Obstacle and Gambler's Choice (But not limited to below list)**

- A. Bridge (4x8 plywood turned sideways) Note: Plastic tarp NOT recommended due to hazard of getting caught up in wheels.)
- B. Back and Bump (U shaped logs with back pole on top so bump knocks it onto ground)
- C. Mailbox
- D. Gee / Haw Maneuver (cut-under vehicle have advantages but any rig can be used to prove ability)
- E. Cone Weave (Tennis balls on top of cones in cone pattern aids in viewing errors plus increases degree of difficulty.)
- F. In and Out Box (Long three sided box with cone or log in center – allow for adjusting for different size vehicles as well as single/multiple)
- G. Log Wheel Slot (For single hitches only – animals in the way for multi-hitch.)
- H. Wheel in Circle Pivot (For Single Hitches only)
- I. Back Through (Logs or cones)

NOTE: To create parity in a class with various sized vehicles, measure the vehicle widths to the outside of the tires, line up contestants in ascending order, and change cone or pole widths to be wheels plus 15 inches.

## **VII. CLASS RULES – WESTERN PERFORMANCE**

### **7.1 General Western Performance Class**

- A. Donkeys and mules will be shown separately. (Exception: Although it is not recommended to show donkeys and mules in the same class, they may be combined for Novice and Green classes if designated as such on the show flyer.)
- B. In all judged Western Performance riding, the following rules apply to use of number of hands on reins:
  - 1. Donkey-Both hands on reins, using any approved bit either snaffle/bosal or curb, will be permitted, but may be penalized (i.e. Advantage goes to exhibitor riding one-handed whose performance is equal to a two-handed rider.) Exception: In Green class using snaffle/bosal, donkey must be ridden with two hands.

## 2. Mule

- a. Adult/Open - Reins shall be held in one hand and cannot be changed during performance. The free hand shall not be used to support the rider by being placed on any part of the saddle.
- b. Green - Two hands must be used with the proper equipment. Recorded Green animals may be ridden with two hands in any class.
- 3. Sub-Youth - The same rules that apply to all other Western Performance divisions regarding hands, reins and bits, also apply in the Sub-Youth classes. (For safety, split reins should be "joined" in some unobtrusive manner.)
- C. **Patterns may be posted on the website prior to the start of the show, or at the venue no less than 1 hour prior to the class itself.**
- D. See Section 2.1 for Attire Rules.
- E. See Section 3.2 for Equipment Rules

## **7.2 Western Pleasure**

- A. Animals may be classed by height.
- B. Will be shown both ways of the ring at a walk, jog and lope on a reasonably loose rein or light contact without undue restraint. Requesting an extension of any gait is at the option of the judge.
- C. Will be asked to back.
- D. Reversing on the rail is always done to the inside.
- E. Judged on performance (quality of movement, attitude and correctness); the condition and conformation of an animal will not be judged directly but as a part of the overall result as presented in the performance.
- F. Description of an ideal performance to include: A free-flowing stride of reasonable length in keeping with conformation; cover a reasonable amount of ground with little effort; ideally, have a balanced, flowing motion; carry head and neck in a relaxed, natural position, with poll level with or slightly above the level of the withers; should not carry head behind the vertical,

giving the appearance of intimidation, or be excessively nosed out, giving a resistant appearance; head should be level with nose slightly in front of the vertical, having a bright expression with ears alert; shown on a reasonably loose rein, but still have light contact and control; should be responsive, yet smooth in transitions when called for; when asked to extend, should move out with same flowing motion; maximum credit should go to the flowing, balanced and willing animal which gives the appearance of being fit and a pleasure to ride.

#### G. Faults to be scored according to severity:

1. Excessive speed (any gait)
2. Being on the wrong lead
3. Breaking gait
4. Excessive slowness in any gait, loss of forward momentum
5. Failure to take the appropriate gait when called for
6. Touching animal or saddle with free hand
7. Head carried too high
8. Head carried too low (tip of ear below the withers for five or less strides)
9. Overflexing or straining neck in head carriage so the nose is carried behind the vertical for five or less strides
10. Excessive nosing out
11. Opening mouth excessively
12. Stumbling or falling
13. Use of spurs or romal forward of the cinch
14. If animal appears sullen, dull, lethargic, emaciated, drawn or overly tired
15. Quick, choppy or pony-strided
16. If reins are draped to the point that light contact is not maintained

#### H. Faults which will be cause for disqualification:

1. Changing hands or two hands on reins, except when showing with a bosal or snaffle bit, or in donkey classes.
2. More than one finger between reins
3. Head carried too low (tip of ear below the withers for more than 5 strides)
4. Overflexing or straining neck in head carriage so the nose is carried behind the vertical for more than 5 strides

#### I. Division specifications:

1. Mule - See "hands" rule (7.1 B 2)

2. Donkey- See "hands" rule (7.1 B 1)
3. Youth
  - a. Backing of animal and loping will be at the judge's option - with consideration given to safety of exhibitors and animals.
  - b. An animal that lopes, even if in the wrong lead, will be given preference over an animal that only trots.
4. Sub-Youth: Donkeys and mules will be shown together. Class will be walk/trot. Adult assistant must be in the arena for each contestant, dress code applies to assistant.
5. Green - Judged as A-H above. May be a walk/trot class if specified on show flyer and all other Western Performance classes titled "Green" are also limited to walk/trot.
6. Novice - May be walk/trot but should be specified on show flyer.

### **7.3 Trail Class**

A. Class judged on the performance of the animal over a series of obstacles such as might be encountered in a cross country ride with emphasis on manners, response to the rider and attitude.

1. Credit to be given:

- a. To those animals negotiating the obstacles with style and some degree of speed, providing carefulness is not sacrificed.
- b. To those animals showing capability of picking their own way through course when obstacles warrant it, and willingly responding to rider's cues on more difficult obstacles.

2. Penalties to be assessed:

- a. To animals for unnecessary delay while approaching the obstacles; however, a true trail animal should be relied upon to investigate an obstacle to determine its safety. An animal will not be penalized for examining obstacles within a reasonable amount of time, if they are then negotiated calmly and safely
- b. For animals with artificial appearance over obstacles, as well as for rider's exaggerated standing in stirrups and leaning forward over

animal's neck.

- c. For rider's obvious cuing animal on the neck or anywhere forward of the cinch.
- d. Severely for failure to complete an obstacle or doing it differently from the pattern (not a disqualification but no score for that obstacle).

3. Disqualification results upon failure to follow the course.

4. The judge has the right and duty to alter the course in any manner or remove any obstacle he deems unsafe.

B. Three refusals at any one obstacle, exhibitor must proceed to next obstacle.

C. No animal which deviates from the pattern in any way as it is written on the posted course shall place above any animal that completes the pattern as written.

D. Division specifications:

1. Mule - Only one hand may be used on the reins, except that it is permissible to change hands to work an obstacle. Exception: When showing with snaffle or bosal.

2. Donkey - (See "hands "rule 7.1 B1) If one hand used, same as for Mules.

3. Youth - Same rules as adult.

4. Sub-Youth: Donkeys and mules will be shown together. Recommended limit of 3 obstacles. (No gate or side pass) No loping. Tack must be suitable to size of rider. Adult assistant must be in arena, dress code applies to assistant.

5. Green - Same rules, simpler pattern.

6. Novice-Same rules, simpler pattern.

E. Course Requirements

1. No rail work, but course must be designed to require each animal to show the three gaits (walk, trot, lope) somewhere between obstacles as part of its work. (Exceptions: Sub-Youth limited to walk/trot, and

Green and Novice classes can be walk/trot.) Enough space must be provided for an animal to jog (at least 30 feet) and lope (at least 50 feet) for the judge to evaluate these gaits.

2. At least six obstacles will be used, two must be chosen from the mandatory list and the remainder chosen from the mandatory or the optional list or at the discretion of the show management as long as they do not appear on the Prohibited Obstacle list. (Exception: Sub-Youth class recommendation is a total of three obstacles.)

#### F. Obstacle list

##### 1. Mandatory obstacles (must use two from this list)

a. Opening, passing through and closing gate. (Losing control of gate is to be penalized.) Use of the actual arena gate so that a contestant is outside of arena is not recommended, however, if absolutely necessary, then an area must be marked off or flagged to keep other animals and people out of the working area. Gate used must not endanger animal or rider.

b. Ride over at least four logs or poles. These can be in a straight line, curved, zigzagged or raised. The space between the logs is to be measured and the path the animal is to take should be the measuring point. Trot overs and lope overs can only be elevated for adult and open classes. All elevated elements must be placed in a cup, notched block or otherwise secured so they cannot roll. The height should be measured from the ground to the top of the element. The space for walkovers, trot overs and lope overs shall be as follows or increments thereof.

(1.) The spacing for walk overs shall be 20-24" and maybe elevated to 12" period. Elevated walk overs should be set a least 22" apart.

(2.) The spacing for trot overs shall be 3' to 3'6" and maybe elevated to 8".

(3.) The spacing for lope-overs shall be 6' to 7' or increments thereof and maybe elevated to 8".

c. Backing obstacle. Backing obstacles to be spaced a minimum of 28"; if elevated, 30" spacing is required.

(1) Back through and around at least three markers.

(2) Back through L,V,U, straight, or similar shaped course. May be elevated no more than 24".

2. Optional obstacles, but not limited to:

- a. Water hazard (ditch or small pond). Water boxes used must not have a metal or slick bottom.
- b. Serpentine obstacles at walk or jog. Spacing to be minimum of 6' for jog.
- c. Carry object from one part of arena to another. (Only objects which reasonably might be carried on a trail ride may be used.)
- d. Ride over wooden bridge. (Suggested minimum width shall be 36" wide and at least six feet long.) Bridge should be sturdy and safe. (Gait over an elevated bridge must be a walk.)
- e. Put on and remove slicker.
- f. Remove and replace materials from mailbox.
- g. Side pass (may be elevated to 12" maximum).
- h. An obstacle consisting of four logs or rails, each 5' to 7' long, laid in a square. Each contestant will enter the square by riding over log or rail as designated. When all four feet are inside the square, rider should execute a turn, as indicated, and depart.
- I. Hides (not green) may be used but not in such a manner that an animal is required to step directly on the hide.
- j. Dismounting is allowed with the following notation: A rider with ANY TYPE of handicap which would affect mounting/dismounting will be allowed to have assistance without any penalty since what is being judged in this class is not the style and grace of the mounting/dismounting rider, but the manners and obedience of the animal. Also, it is HIGHLY RECOMMENDED due to time considerations, if used, this obstacle be placed last in the course so remounting is not necessary.
- k. Very low "jumps" or cavalletti representing what the average rider might attempt in a normal trail ride may be used. (Maximum height: 18 inches)
- I. Any other safe and negotiable obstacle which could reasonably be expected to be encountered on a trail ride and meets the approval of the judge may be used.
- m. A combination of two or more of any of the obstacles is acceptable.

3. Prohibited obstacles:

- a. PVC pipe
- b. Rocking or moving bridges
- c. Water box with floating or moving parts
- d. Flames, dry ice, fire extinguisher, etc.
- e. Logs or poles elevated in a manner that permits such to roll
- f. Tires (not to be used as an item to be negotiated but may be part of the "scenery")
- g. Animals

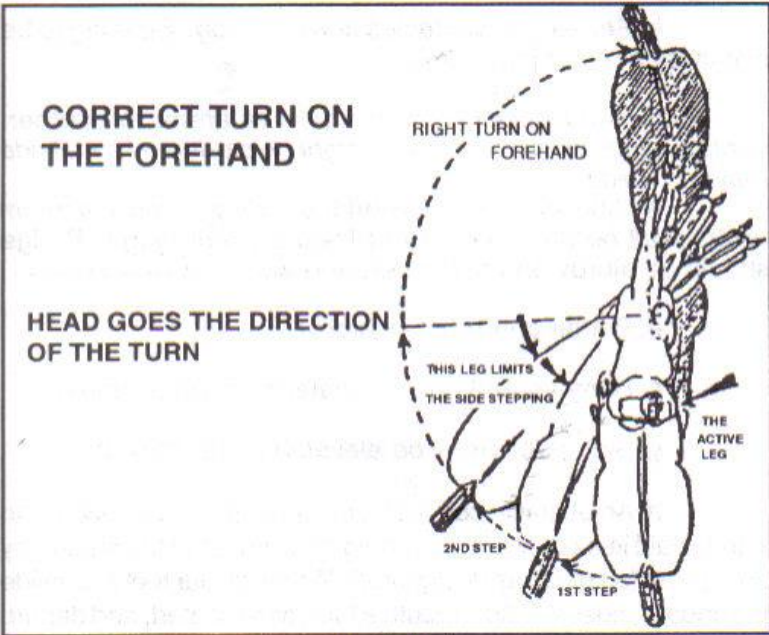

Turn on Haunches

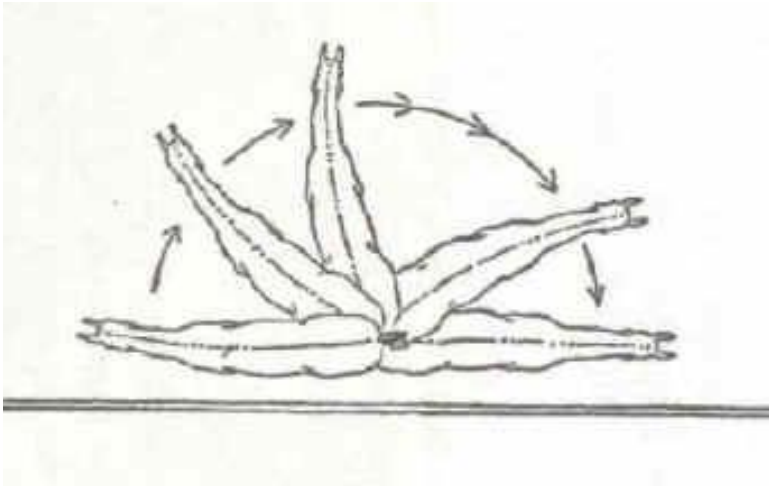

# TRAIL OBSTACLES

## BACK THROUGH AND AROUND THREE MARKERS

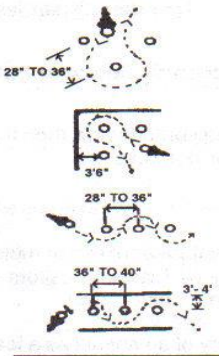

## VARIATIONS OF L BACK THROUGH

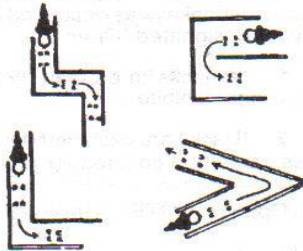

## VARIATIONS OF SIDEPASS

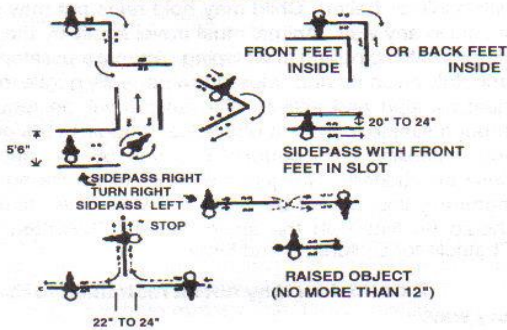

## TROT AND LOPE OVERS

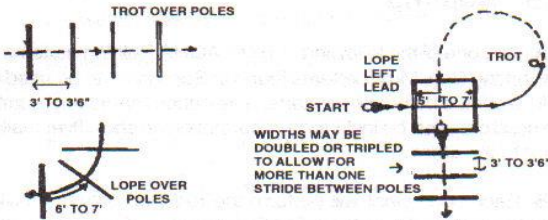

## WALK OVERS



This Page Intentionally Left Blank

## 7.4 Lead Line Obstacle

A. It is not recommended that donkeys and mules compete against each other, however, donkeys and mules may be shown separately or together in any combination in this class except for donkeys as described below. No riders. This class may be designated "Open".

### 1. No jacks to be lead by or ridden by Youth or Sub-Youth age exhibitor.

2. If jacks are excluded due to the youth factor, then this class cannot be counted for points for donkeys.

B. Options: NOTE: (The chosen class option to be clearly stated on the show flyer.)

1. As a lead line trail class for miniature donkeys or mules and young or very green animals. May be lead with halters or bridles for donkeys. No riders. May be a point class. See miniature section for specific miniature rules.

2. As a class to judge the suitability of an animal as a lead mount for a child 8 years and under. To be shown under saddle, with bridle or halter. Child may hold reins but may not control animal in any way. Animal must travel easily by the side of the handler with no pulling or whipping. Animal must stop easily and smoothly on command. Must show perfectly gentle manners but must be alert and active. The animal will be required to go through simple, common obstacles. Judged 75% on manners and suitability, 20% performance and 5% on appointments. Child not judged. No jacks allowed to be ridden by youth therefore this cannot be a point class. This mounted class should be listed on the show flyer as "Mounted Lead Line Obstacle for Children 8 and Under".

A. Child rider may not be restrained to the saddle in anyway.

## 7.5 Reining

A. Any one of the following patterns or the 3 Working Cow Mule patterns found in Section XI to be used which will be posted before show starts. The pattern name and number to be used can also be included in information on show flyer mailed out prior to the show.

B. Each contestant will perform the required pattern individually and

separately. All mules will be judged immediately upon entering the arena and judging will cease after the last maneuver. Any fault incurred prior to the commencement of a pattern will be scored accordingly.

C. To rein a mule is not only to guide him, but also to control his every movement. The best reined mule should be willfully guided or controlled with little or no apparent resistance and dictated to completely. Any movement on his own must be considered a lack of control. All deviations from the exact written pattern must be considered a lack of or temporary loss of control, and therefore faulted according to severity of deviation. Credit will be given for smoothness, finesse, attitude, quickness and authority in performing the various maneuvers while using controlled speed.

D. Scoring will be on the basis of 0-infinity, with 70 denoting an average performance.

1. The following will result in no score:

- a. Abuse of an animal in the show arena and/or evidence that an act of abuse has occurred prior to or during the exhibition of a mule in competition
- b. Use of illegal equipment, including wire on bits, bosals or curb chains
- c. Use of illegal bits, bosals or curb chains
- d. Use of tack collars, tie downs or nose bands. Use of whips or bats
- f. Use of any attachment which alters the movement of the tail
- g. Failure to provide horse and equipment to the appropriate judge for inspection
- h. Disrespect or misconduct by the exhibitor

2. A rider may untangle excess rein, where excess rein may prevent the rider from continuing the pattern, where excess can be straightened without affecting the performance of the mule, during hesitations, or when settling a mule; rider's free hand may be used to hold romal in the normal fashion.

3. The following will result in a score of 0:

- a. Use of more than index or first finger between reins
- b. Use of two hands or changing hands (exception in Green class or when Green animals are ridden in Open/Adult classes)
- c. Use of romal other than as outlined in III 3.2 B5
- d. Failure to complete pattern as written
- e. Performing the maneuvers other than in specified order
- f. The inclusion of maneuvers not specified, including, but not limited to  
(1) Backing more than 2 strides

(2) Turning more than 90 degrees

g. Equipment failure that delays completion of pattern

h. Balking or refusal of command where pattern is delayed

i. Running away or failing to guide where it becomes impossible to discern whether the entry is on pattern

j. Overspins of more than 1/4 turn

k. Fall to the ground by mule or rider. Neither a "No Score" nor a "0" are eligible to place in a class.

4. The following will result in a reduction of five points:

a. Spurring in front of cinch

b. Use of free hand to instill fear

c. Holding saddle or touching horse with free hand

d. Blatant disobediences including kicking, biting, bucking and rearing

5. The following will result in a reduction of two points:

a. Failure to go beyond markers on stops or rollbacks

b. Break of gait

c. Freeze up in spins or rollbacks

d. On walk in patterns, failure to stop or walk before executing a canter departure.

e. On run in patterns, failure to be in a canter prior to the first marker.

6. Starting or performing circles or eights out of lead will be judged as follows:

a. Each time an animal is out of lead, a judge is required to deduct one point.

b. The penalty for being out of lead is accumulative and the judge will deduct one penalty point for each quarter of the circumference of a circle or any part thereof that an animal is out of lead.

c. A judge is required to penalize an animal 1/2 point for a delayed change of lead by one stride.

7. Deduct 1/2 point for starting circle at a jog or exiting rollbacks at a jog up to two strides. Jogging beyond two strides, but less than 1/2 circle or 1/2 the length of the arena, deduct two points.

8. Deduct 1/2 point for over or under spinning up to 1/8 of a turn; deduct 1 point for over or under spinning from 1/8 to 1/4 turn.

9. A 1/2 point penalty deduction will be given for failure to remain a minimum of 20 feet from the wall or fence when approaching a stop and/or rollback.

10. Where a change of lead is specified immediately prior to a run to the end of the pen, failure to change leads will be penalized as follows: failure to change leads by one stride -1/2 point; failure to change leads beyond one stride, but where lead change is completed prior to next maneuver - one point; lead is not changed prior to the next maneuver - two points; in patterns requiring a run-around, failure to be on the correct lead when rounding the end of the arena will be penalized one point. Failure to be on the correct lead prior to the center point of the arena will be a two point penalty.

E. A judge may require any contestant to repeat his performance of any or all of the various parts of the pattern.

F. Faults against the mule (to be scored accordingly, but not to cause disqualification):

1. Opening mouth excessively when wearing bit
2. Excessive jawing, open mouth or head raising on stop
3. Lack of smooth, straight, stop on haunches (bouncing or sideways stop)
4. Refusing to change leads
5. Anticipating signals
6. Stumbling
7. Backing sideways
8. knocking over markers

G. Faults against the rider (to be scored accordingly, but not to cause disqualification):

1. Losing stirrup
2. Any unnecessary aid given by the rider (such as unnecessary talking, petting, spurring, quirting, jerking of reins, etc.)
3. Failure to run circles or figure eights within the markers is not considered a fault depending on arena conditions and size; however, failure to go beyond markers on rollbacks and stops is considered a fault.

H. While mule is in motion, rider's hands shall be clear of mule and saddle.

## REINING PATTERN NUMBER 1

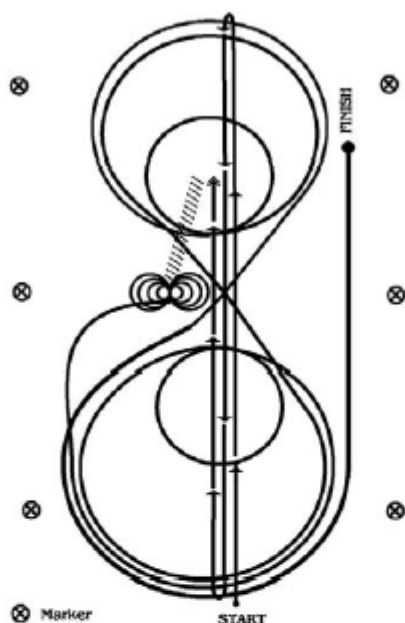

1. Run at speed to the far end of the arena past the end marker and do a left rollback - no hesitation.

2. Run to the opposite end of the arena past the end marker and do a right rollback - no hesitation.

3. Run past the center marker and do a sliding stop. Back up to center of the arena or at least ten feet (3 meters). Hesitate.

4. Complete four spins to the right.

5. Complete four and one-quarter spins to the left so that horse is facing left wall or fence. Hesitate.

6. Beginning on the left lead, complete three circles to the left: the first circle large and fast; the second circle small and slow; the third circle large and fast. Change leads at the center of the arena.

7. Complete three circles to the right: the first circle large and fast; the second circle small and slow; the third circle large and fast. Change leads at the center of the arena.

8. Begin a large fast circle to the left but do not close this circle. Run straight up the right side of the arena past the center marker and do a sliding stop at least 20 feet (6 meters) from wall or fence. Hesitate to demonstrate the completion of the pattern.

Rider may drop bridle to the designated judge.

## REINING PATTERN NUMBER 2

(AQHA 1996)

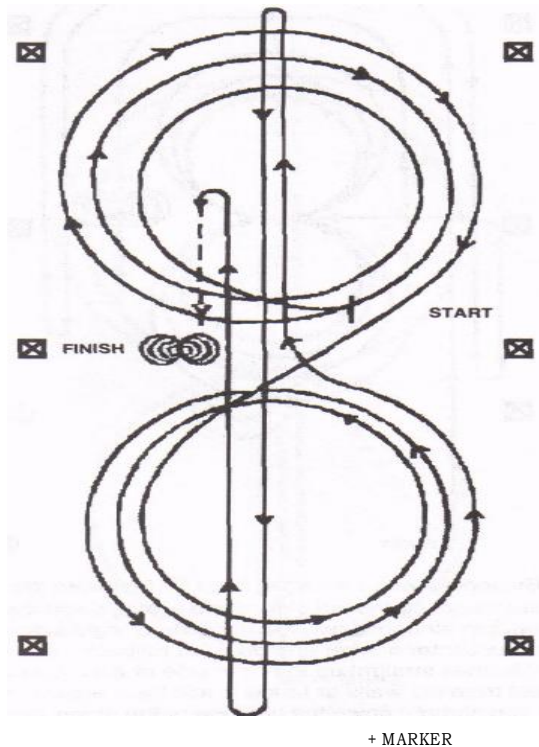

Beginning at the center of the arena facing the left wall or fence.

1. Beginning on the right lead, complete 3 circles to the right: the first circle small and slow; the next two circles large and fast. Change leads at the center of the arena.
  2. Complete 3 circles to the left: the first circle small and slow; the next 2 circles large and fast. Change leads at the center of the arena.
  3. Run up the middle to the far end of the arena past the end marker and do a left rollback - no hesitation.
  4. Run to the opposite end of the arena past the end marker and do a right rollback - no hesitation.
  5. Run past the center marker and do a sliding stop. Back up to the center of the arena or at least 10 feet. Hesitate.
  6. Complete 4 spins to the right.
  7. Complete 4 spins to the left. Hesitate to demonstrate completion of the pattern.
- Rider may drop bridle to the judge.

## REINING PATTERN NUMBER 3

(AOHA 1996)

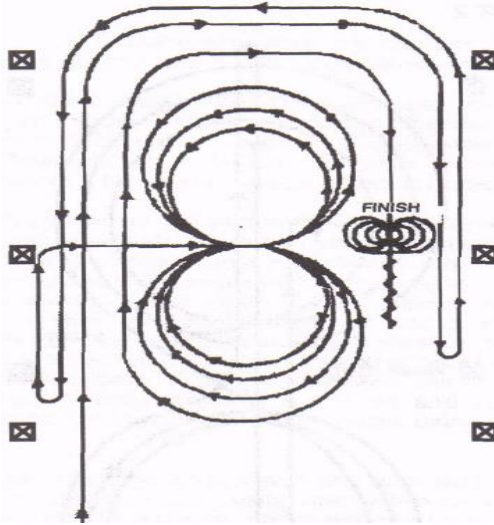

1. Beginning, and staying at least 20 feet from the walls or fence, lope straight up the left side of the arena, circle the top end of the arena, run straight down the opposite or right side of the arena past the center marker and do a left rollback - no hesitation.
  2. Continue straight up the right side of the arena staying at least 20 feet from the walls or fence, circle back around the top of the arena, run straight down the left side of the arena past the center marker and do a right rollback - no hesitation.
  3. Continue up the left side of the arena to the center marker. At the center marker, the mule should be on the right lead. Guide the mule to the center of the arena on the right lead and complete 3 circles to the right: the first 2 circles large and fast; the third circle small and slow. Change leads at the center of the arena.
  4. Complete 3 circles to the left: the first 2 circles large and fast; the third circle small and slow. Change leads in the center of the arena.
  5. Begin a large fast circle to the right but do not close this circle. Continue up the left side of the arena staying at least 20 feet from the walls or fence, circle the top of the arena, run straight down the opposite or right side of the arena past the center marker and do a sliding stop. Back up at least 10 feet. Hesitate.
  6. Complete 4 spins to the right.
  7. Complete 4 spins to the left. Hesitate to demonstrate completion of the pattern.
- Rider may drop bridle to the judge.

## REINING PATTERN NUMBER 4

(AQHA 1996)

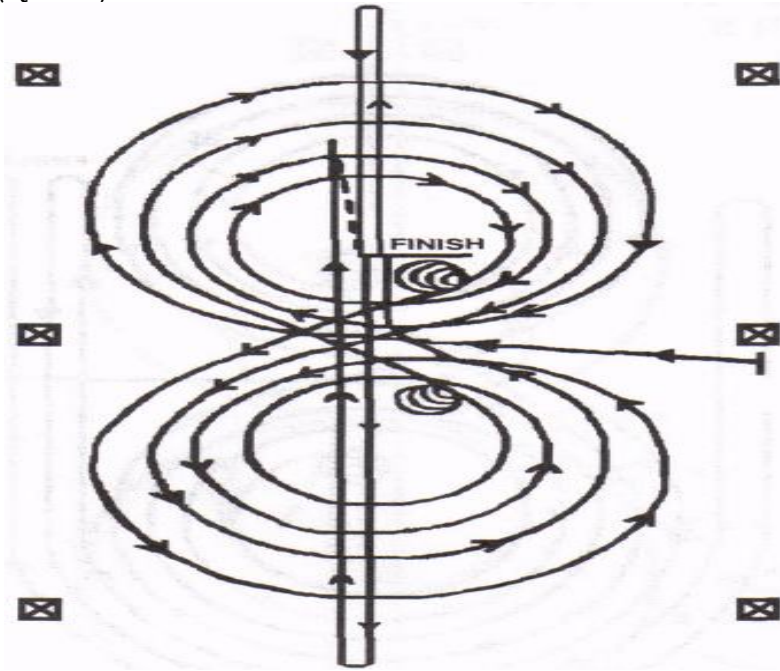

Beginning at the center of the arena facing the left wall or fence.

1. Beginning on the right lead, complete 3 circles to the right: the first 2 circles large and fast; the third circle small and slow. Stop at the center of the arena.
2. Complete 4 spins to the right. Hesitate.
3. Beginning on the left lead, complete the 3 circles to the left: the first 2 circle large and fast; the third circle small and slow.
4. Complete 4 spins to the left. Hesitate.
5. Beginning on the right lead, run a large fast circle to the right, change leads at the center of the arena, run a large fast circle to the left, and change leads at the center of the arena.
6. Run up the middle to the far end of the arena past the end marker and do a left rollback - no hesitation.
7. Run to the opposite end of the arena past the end marker and do a right rollback - no hesitation.
8. Run past the center marker and do a sliding stop. Back up at least 10 feet. Hesitate to demonstrate completion of the pattern.  
Rider may drop bridle to the judge.

## REINING PATTERN NUMBER 5

(AQHA 1996)

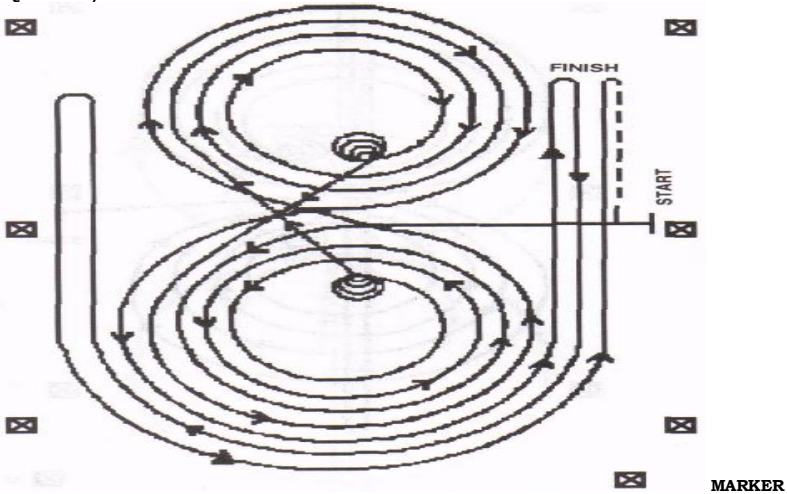

Beginning at the center of the arena facing the left wall or fence.

1. Beginning on the left lead, complete 3 circles to the left: the first 2 circles large and fast; the third circle small and slow. Stop at the center of the arena.
  2. Complete 4 spins to the left. Hesitate.
  3. Beginning on the right lead, complete 3 circles to the right: the first 2 circles large and fast; the third circle small and slow. Stop at the center of the arena.
  4. Complete 4 spins to the right. Hesitate.
  5. Beginning on the left lead, run a large fast circle to the left, change leads at the center of the arena, run a large fast circle to the right, and change leads at the center of the arena.
  6. Continue around previous circle to the left but do not close this circle. Run up the right side of the arena past the center marker and do a right rollback at least 20 feet from the wall or fence - no hesitation.
  7. Continue around previous circle but do not close this circle. Run up the left side of the arena past the center marker and do a left rollback at least 20 feet from the wall or fence - no hesitation.
  8. Continue back around previous circle but do not close this circle. Run up the right side of the arena past the center marker and do a sliding stop at least 20 feet from the wall or fence. Back up at least 10 feet. Hesitate to demonstrate completion of the pattern.
- Rider may drop bridle to the judge.

## REINING PATTERN NUMBER 6

(AQHA1996)

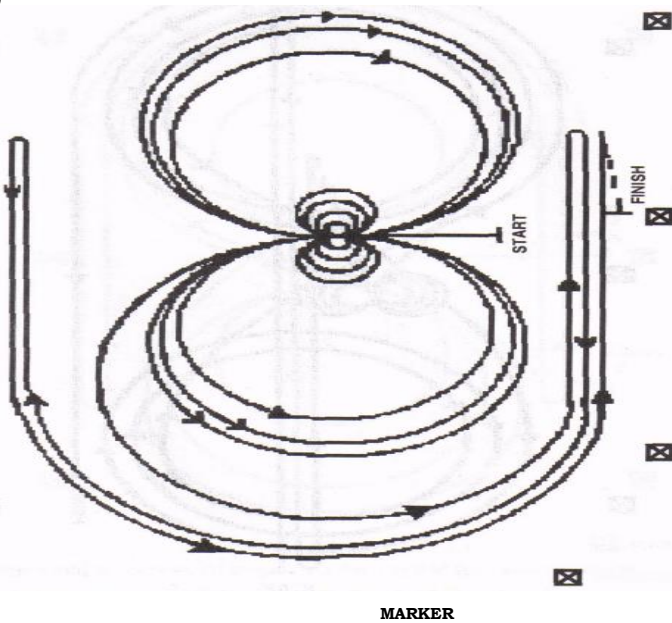

Beginning at the center of the arena facing the left wall or fence.

1. Complete 4 spins to the right.
  2. Complete 4 spins to the left. Hesitate.
  3. Beginning on the left lead, complete 3 circles to the left: the first 2 circles large and fast; the third circle small and slow. Change leads at the center of the arena.
  4. Complete 3 circles to the right: the first 2 circles large and fast; the third circle small and slow. Change leads at the center of the arena.
  5. Begin a large fast circle to the left but do not close this circle. Run up the left side of the arena past the center marker and do a right rollback at least 20 feet from the wall or fence - no hesitation.
  6. Continue back around previous circle but do not close this circle. Run up the left side of the arena past the center marker and do a left rollback at least 20 feet from the wall or fence - no hesitation.
  7. Continue back around previous circle but do not close this circle. Run up the right side of the arena past the center marker and do a sliding stop at least 20 feet from the wall or fence. Back up at least 10 feet. Hesitate to demonstrate completion of the pattern.
- Rider may drop bridle to the judge.

## REINING PATTERN NUMBER 7

(AOHA 1996)

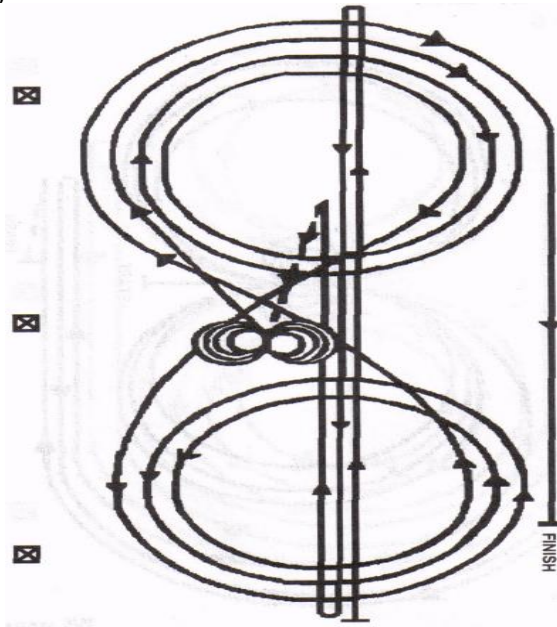

1. Run at speed to the far end of the arena past the end marker and do a left rollback - no hesitation.
  2. Run to the opposite end of the arena past the end marker and do a right rollback - no hesitation.
  3. Run past the center marker and do a sliding stop. Back up to the center of the arena at least 10 feet. Hesitate.
  4. Complete 4 spins to the right.
  5. Complete 4 and one-quarter spins to the left so that mule is facing left wall or fence. Hesitate.
  6. Beginning on the right lead, complete 3 circles to the right: the first 2 circles large and fast; the third circle small and slow. Change leads at the center of the arena.
  7. Complete 3 circles to the left: the first 2 circles large and fast; the third circle small and slow. Change leads at the center of the arena.
  8. Begin a large fast circle to the right but do not close this circle. Run straight down the right side of the arena past the center marker and do a sliding stop at least 20 feet from the wall or fence. Hesitate to demonstrate completion of the pattern.
- Rider may drop bridle to the judge.

## REINING PATTERN NUMBER 8

(AQHA 1996)

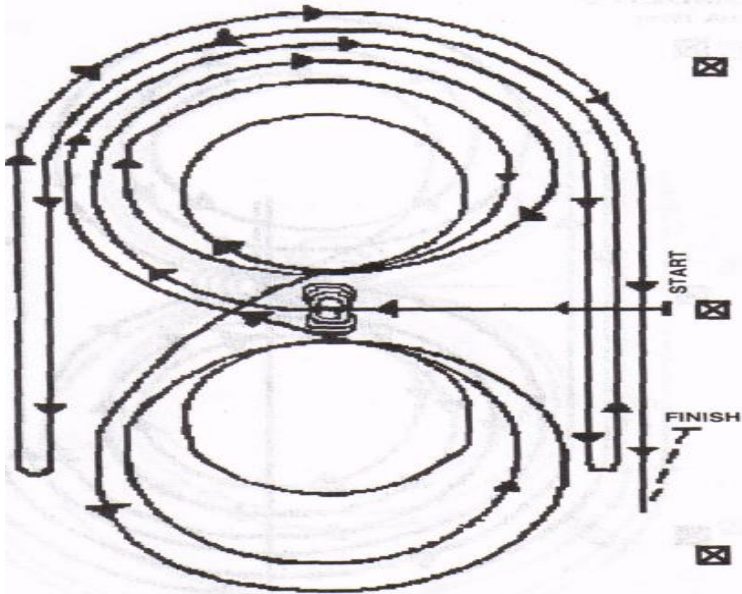

Walk mule to center of the arena facing the left wall or fence.

1. Complete 4 spins to the left.
2. Complete 4 spins to the right. Hesitate.
3. Beginning on the right lead, complete 3 circles to the right: the first circle large and fast; the second circle small and slow; the third circle large and fast. Change leads at the center of the arena.
4. Complete 3 circles to the left: the first circle large and fast; the second circle small and slow; the third circle large and fast. Change leads at the center of the arena.
5. Begin a large fast circle to the right but do not close this circle. Run straight down the right side of the arena past the center marker and do a left rollback at least 20 feet from the wall or fence -no hesitation.
6. Continue back around the previous circle but do not close this circle. Run down the left side of the arena past the center marker and do a right rollback at least 20 feet from the wall or fence - no hesitation.
7. Continue back around the previous circle but do not close this circle. Run down the right side of the arena past the center marker and do a sliding stop at least 20 feet from the wall or fence. Back up at least 10 feet. Hesitate to demonstrate completion of the pattern.

Rider may drop bridle to the judge.

## REINING PATTERN NUMBER 9

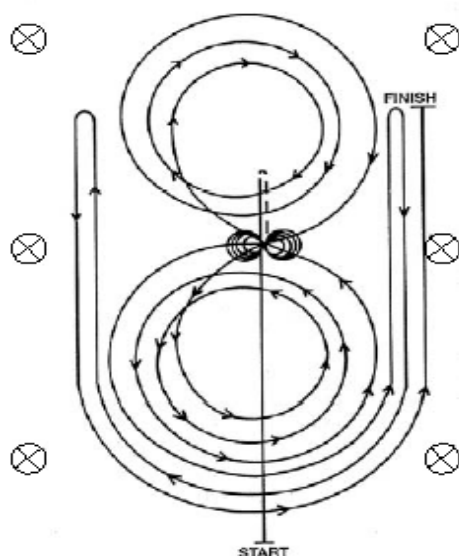

1. Run past the center marker and do a sliding stop. Back up to the center of the arena or at least 10 feet (3 meters). Hesitate.

2. Complete four spins to the right.

3. Complete four and one-quarter spins to the left so that horse is facing the left wall or fence. Hesitate.

4. Beginning on the left lead, complete three circles to the left: the first circle small and slow; the next two circles large and fast. Change leads at the center of the arena.

5. Complete three circles to the right: the first circle small and slow; the next two circles large and fast. Change leads at the center of the arena.

6. Begin a large fast circle to the left but do not close this circle. Run up the right side of the arena past the center marker and do a right rollback at least 20 feet (6 meters) from the wall or fence - no hesitation.

7. Continue back around the previous circle but do not close this circle. Run up the left side of the arena past the center marker and do a left rollback at least 20 feet (6 meters) from the wall or fence - no hesitation.

8. Continue back around previous circle but do not close this circle. Run up right side of the arena past the center marker and do a sliding stop at least 20 feet (6 meters) from the wall or fence. Hesitate to demonstrate completion of the pattern.

Rider may drop bridle to the designated judge.

# REINED WORKING DONKEY PATTERN 1

(TAYLOR/NUNN 1996)

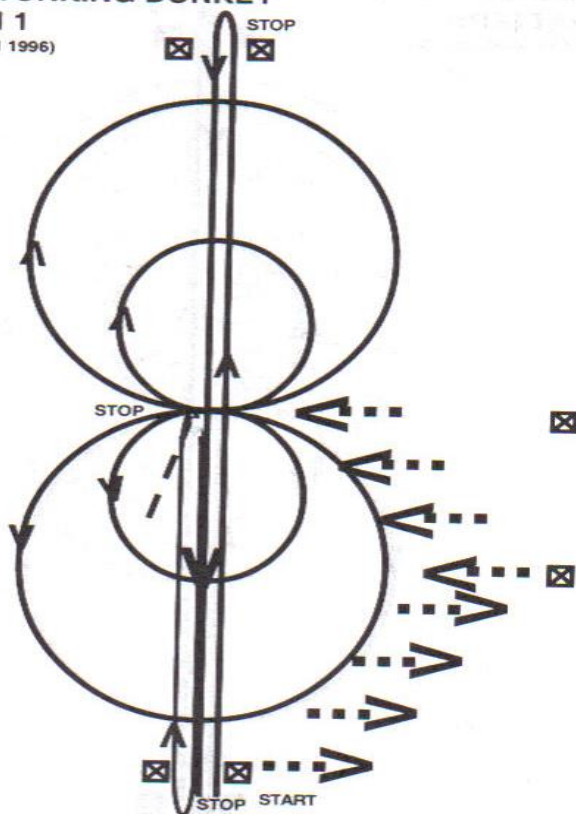

1. Start trotting at designated cone and demonstrate lateral movement (sidepass) at the trot to the right; at next cone, without stopping, demonstrate lateral movement (sidepass) at the trot to the left. Stop at center of arena. Hesitate. Do a quarter turn left to face left center arena wall.
  2. Take a right lead and make 2 circles to the right, the first small and slow and the second large and fast.
  3. Do a simple lead change at the center of the arena.
  4. Make 2 circles to the left, the first small and slow, and the second large and fast.
  5. Do a simple lead change at the center of the arena.
  6. Hand gallop between and past cones at far end of arena.
- Stop.
7. Turn on haunches to left and hand gallop between and past cones at near end of arena. Stop.
  8. Turn on haunches to the right and hand gallop to center of arena. Stop.
  9. Back (straight) at least 10 feet.
  10. Walk to judge and stop for inspection if requested, exit arena at a trot.

**REINED WORKING DONKEY  
PATTERN 2**

(TAYLOR/NUNN1996)

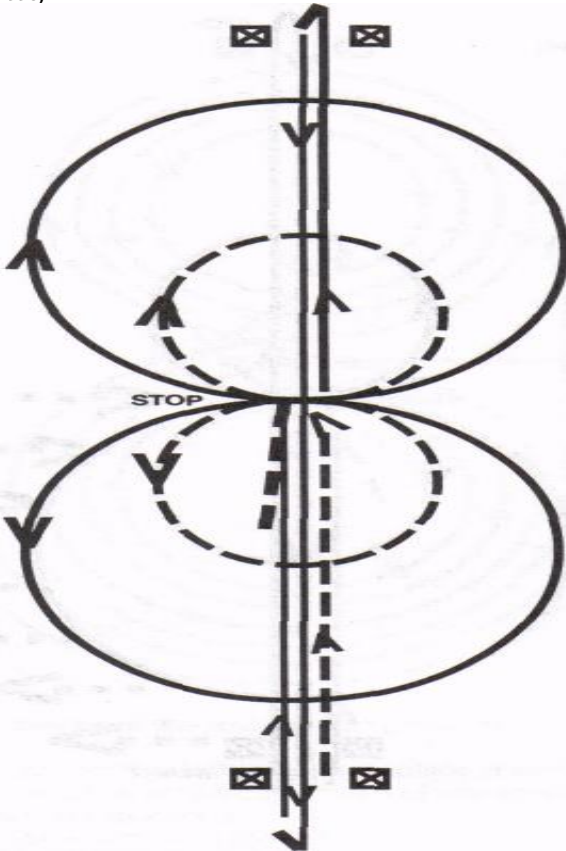

1. Starting at designated cone, trot to center of arena and then trot a small Figure 8 pattern.
2. At center of arena, lope on the right lead to the right in a large circle.
3. At center of arena, do a simple lead change and lope in a large circle to the left.
4. At center of arena, do a simple lead change and lope between and past cones at far end of arena. Stop.
5. Turn on haunches to left and lope between and past cones at near end of arena. Stop.
6. Turn on haunches to the right and lope to center of arena. Stop.
7. Back at least 10 feet.
8. Walk to judge and stop for inspection if requested. Exit at a trot.

# REINED WORKING DONKEY PATTERN 3

Taylor/Nunn 2000

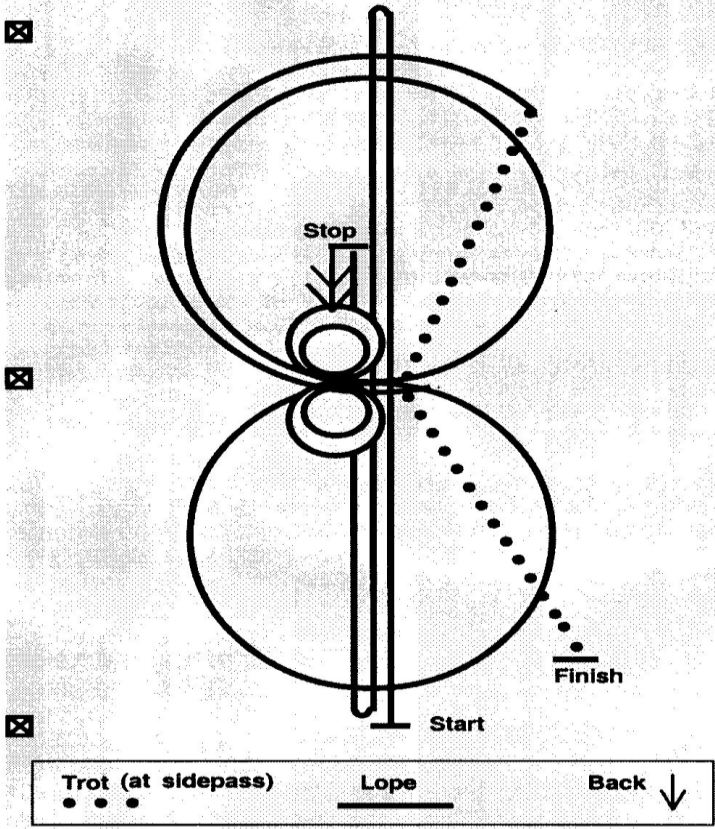

1. Run at speed to the far end of the arena past the end marker and do a left rollback, no hesitation.
2. Run to the opposite end of the arena past the end marker and do a right rollback, no hesitation.
3. Run past the center marker and stop. Back to the center of the arena (at least 10 feet), hesitate.
4. Complete 2 spins to the right
5. Complete 2 1/4 spins to the left. Hesitate.
6. Complete one large circle to the right at a lope, and at the center of the arena, change to the left lead.
7. Complete one large circle to the left at a lope, and at the center of the arena change to the right lead.
8. Begin a large circle to the right and at the end markers, break to a trot.
9. At the trot, side pass to the right to the center of arena.
10. At the center, without hesitation, side pass to the left end marker.
11. Stop. Acknowledge judge for dismissal.

## **7.6 Reined Working Donkey**

- A. In contrast to Donkeymanship, this class is intended to evaluate the donkey and its willingness to be controlled.
- B. Either of the 3 patterns on the prior pages may be used. The pattern number can be included in information on the show flyer mailed prior to the show. It is suggested that the more difficult Patterns, # 1 or 3, be used at larger shows and the easier Pattern #2 be used at smaller shows for practice.
- C. Each contestant will perform the required pattern individually and separately. To rein a donkey is not only to guide him, but also to control his every movement. The best reined donkey should be willingly guided or controlled with little or no apparent resistance and dictated to completely. Any movement on his own must be considered a lack of control. All deviations from the exact written pattern must be considered a lack of or temporary loss of control, and therefore faulted according to severity of deviation. Credit will be given for smoothness, finesse, attitude, quickness and authority in performing the various maneuvers while using controlled speed.
- D. Donkeys may be shown with any approved bit, either snaffle/bosal or curb, using one or two hands. Given equal performance, a donkey ridden with one hand should be placed above one ridden with two hands. Exception: Green classes must be ridden with two hands.

## **7.7 Western Mulemanship/Donkeymanship**

- A. Judging: Riders will be judged on seat, hands, ability to control and show animal. Results as shown by performance of the animal are NOT to be considered more important than the method used by the rider.
- B. Basic Position: The rider should sit in the center of the saddle with legs hanging to form a straight vertical line, from the ear, dropping down through the center of the shoulder and hips, touching the back of the heel. Stirrup length should allow heels to be lower than toes, with a slight bend in knee and toe directly under knee. Body should always appear comfortable, relaxed and flexible, and back should be nearly flat. Stiff and/or arched lower back should be avoided. Feet may be placed home in the stirrup, with boot heel touching the stirrup, or may be placed with ball of foot in the stirrup. Riding with toes only in stirrup will be penalized.

C. Hands: Both hands and arms should be held in a relaxed easy manner, with the shoulders back and down, and upper arm in a straight line with the body, the arm holding the reins bent at elbow forming a straight line from the elbow to the animal's mouth. When using a romal, the rider's off hand shall be around romal with at least 16 inches of rein between the hands wrists are to be kept straight and relaxed, with thumb on top and closed around the reins. Index finger between the reins is permitted when using split reins, but not with romal. Some movement of the arm is permissible, but excessive pumping will penalized. Reins are to be carried immediately above or slightly in front of saddle horn. Only one hand is to be used for reining, and hand shall not be changed. Reins should be carried to have light contact with the animal's mouth and at no time reins be carried more than a slight hand movement from the animal's mouth. Excessively loose reins will be penalized (Exceptions to the one hand rule for donkeys and green animals.)

D. Position in Motion: Rider should sit to trot, not post, and remain seated at the lope. Rider should maintain a vertical line at all gaits. All movements of animal should be governed by the use of imperceptible aids. Exaggerated shifting of the rider's weight is not desirable.

E. Mounting and Dismounting: To mount, take up the reins in hand and place hand on withers. Grasp stirrup with right hand insert left foot in stirrup. Placing right hand on horn, mount, To Dismount, rider may either step down or slide down. The size of the rider must be taken into consideration.

F. Appointments: Clothing must be clean, workmanlike and neat. The saddle must fit the rider. It may be slick or swelled fork, having a high or low cantle, but most definitely be sized to the rider.

G. Class Routine: Each rider to work individually. These individual works will be any of the maneuvers the judge feels are necessary to determine the horsemanship ability of the rider and judge will bear this in mind at all times. Individual work may be comprised of any of the following:

1. Walk, jog, trot, lope or gallop in a straight line, curve or circle, or any combination of these gaits and patterns, such as a figure eight, etc.
2. Stop
3. Back
4. Turn on the haunches, including spins and rollbacks, or the forehand
5. Sidepass
6. Simple change of lead through the trot, walk or halt, ie. straight line,

figure 8 or any other pattern

7. Flying change of lead in a straight line, figure 8 or any pattern
8. Counter canter
9. Dismount and mount
10. Ride without stirrups

(Note: Use of markers helps to standardize patterns and guide riders, but they also increase the degree of difficulty somewhat, so their placement should be carefully planned and indicated in the posted pattern and their placement in the arena well supervised.)

H. The judge may use the individual works to determine the top riders to be called back for rail work, and those selected riders will be required to work on the rail.

## **7.8 Western Riding**

A. Western riding is an event where the animal is judged on quality of gaits, lead changes at the lope, response to the rider, manners, and disposition. The animal should perform with reasonable speed, and be sensible, well-mannered, free and easy moving.

B. Credit shall be given for and emphasis placed on smoothness, even cadence of gaits (i.e. starting and finishing pattern with the same cadence), and the animal's ability to change leads precisely and easily, simultaneously both hind and front at the center point between markers. The animal should have a relaxed head carriage showing response to the rider's hands, with a moderate flexion at the poll. Animals may be ridden with light contact or on a reasonably loose rein. (Refer to 7.2 F) The animal should cross the log both at the jog and the lope without breaking gait or radically changing stride.

C. One of the two following patterns may be selected. The judge is responsible for the pattern being correctly set. On the following patterns:

1. The eight small circles represent pylon markers, which are recommended. These should be separated by a uniform measured distance of not less than 30 feet nor more than 50 feet on the side with 5 markers (see diagram). In Pattern 1, the 3 markers on the opposite side should be set adjacent to the appropriate markers. It is recommended that markers be set a minimum of 15 feet from the fence and with 50 to 80 foot width in the pattern, as the arena permits.
2. A solid log or pole should be used and be a minimum of eight feet in length.

3. The long serpentine line indicates the direction of travel and gaits at which the animal is to move. The recommended lead changing point is equal to 1/2 stride length before or after the center point between the markers. The dotted line (...) indicates walk, the dash line (--) jog; and the solid line (\_\_\_) lope.

D. Scoring will be on a basis of 0-100 with 70 denoting an average performance.

1. Scoring guidelines to be considered: points will be added or subtracted from maneuvers on the following basis, ranging from plus 1.5 to minus 1.5: -1.5 extremely poor, -1 very poor, -.5 poor, 0 average, +.5 good, +1 very good, +1.5 excellent. Maneuver scores are to be determined independently of penalty points.

E. A contestant shall be penalized each time the following occur

Five Points:

1. Failure to change leads
2. Kicking out
3. Blatant disobedience

Three Points:

1. Not performing the specific gait (jog or lope) or stopping when called for in the pattern, within 10 feet of the designated area.
2. Break of gait at the lope
3. Simple change of leads
4. Failure to change after one stride but changes before next designated change area
5. Additional lead changes anywhere in pattern
6. In Pattern 1, failure to start the lope within 30 feet after crossing the log at the jog
7. Break of gait at walk or jog up to 2 strides

One point:

1. Break of gait at walk or jog up to 2 strides
2. Hitting or rolling log
3. Failure to change leads for 1 stride
4. Splitting the log (log between the 2 front or 2 hind feet) at the lope

One-half (1/2) point:

1. Tick or light touch of log
2. Hind legs skipping or coming together during lead change
3. Failure to change leads from 1/2 to 1 stride

Disqualified - 0 score:

1. Fall to ground by horse or rider
2. Illegal equipment
3. Willful abuse
4. Off course
5. Knocking over markers
6. Completely missing log
7. Major refusal - stop and back 2 strides or 4 steps with front legs
8. Major disobedience - rearing, schooling
9. Failure to start lope prior to end cone in Pattern 1

Credits:

1. Change of leads, hind and front, simultaneously
2. Changes at designated point
3. Accurate and smooth pattern
4. Even pace throughout
5. Easy to guide and control with rein and leg
6. Manners and disposition
7. Conformation and fitness

F. The following characteristics are considered as faults and should be judged accordingly:

1. Opening mouth excessively or raising head on maneuvers
2. Anticipating signals or early lead changes
3. Stumbling

**WESTERN RIDING  
PATTERN I**  
(AQHA - 1996)

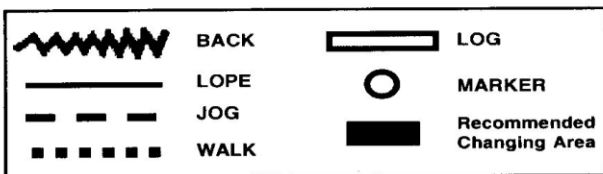
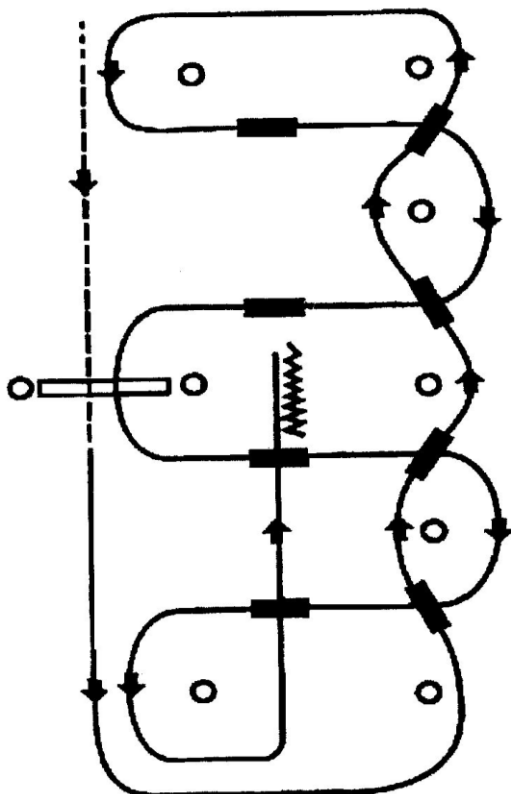

1. Walk & jog over log
2. Transition to lope & lope around end
3. First line change
4. Second line change
5. Third line change
6. Fourth line change & lope around the end of arena
7. First crossing change
8. Second crossing change
9. Lope over log
10. Third crossing change



## 7.9 Command Class

COMMENT: Due to the many problems in getting judges to read and adhere to the rules, as well as the acoustical problems in many arenas, it is suggested this class NOT be used for points but instead be used for "fun" situations.

- A. This class is organized similar to a pleasure riding class and its purpose is to test the skills of the rider and animal by giving commands and eliminating contestants as they fail to respond promptly and correctly. Contestants **must** be called to the center, not left on the rail once they fault out. If it is necessary, in order to see numbers, halting the entire class until those who have been faulted out can be called to the center would be a correct procedure.
- B. Position of Judge: Unless there are extenuating circumstances which prevent it, the judge must judge this class from the announcer's stand or some other appropriate location in the stands where he will have the best view of all the contestants and so his view will not be blocked by the contestants as they fault out to the center. The position in the announcer's stand would also allow the judge to be in direct communication with the announcer (or the judge may announce the commands himself). In positions other than the announcer's stand, the judge (or Ring steward for the judge) must be in radio communication with the announcer. The show committee and judge, together, will make the decision as to the appropriate place to judge the class.
- C. Official Judge: The show judge will be the **ONLY** judge for this class with no judging assistance from anyone else allowed. The judge will never request the contestants to go to the center of the arena under the "honor system".
- D. Ring Assistance in Line-Up: It is suggested that the Ring steward should have at least one assistant to be sure the contestants line up in the center of the ring in the **EXACT** order they are called out so placings will be awarded correctly. (Also see Rule G) They should also be familiar with Rule 7.9 F.
- E. Commands should be spoken distinctly and repeated twice. The sound system must be adequate for the entire arena and outside noises must be considered to be sure that contestants are not

penalized for not hearing the commands.

F. Ties: This class may not result in a tie.

1. When contestants are down to approximately the last 6 for actual placings, if 2 or more contestants fault out at the same command and it is not precisely apparent which one faulted out first, all faulting out at that command should be called into the center and their back numbers noted for a tie for that placing. When the final placings are determined, the tied group will go back out on the rail for a work off. If there is more than one tied group, the groups must be called back to the rail in their own individual units in order of lowest to highest placing groups.

(Example: 8 contestants on the rail, command to counter canter missed by 3 contestants, those 3 contestants to be called in as Tie Group 1; the next command to sidepass missed by 2 contestants who are then called in as Tie Group 2; when remaining class has faulted out in order of placing, Tie Group 1 goes back out on the rail: 1st one out is 8th, next 7th [or if those below 6th place fault out at the same time it doesn't matter - final 6th, then Tie Group 2 goes out on the rail resulting in 5th and 4th places, etc.]

2. Group error: Should all contestants fail to perform a command, the proper procedure would be to announce a total class error and proceed to the next command.

G. The following is a list of all the commands the judge can give for this class. These are the **ONLY** commands to be used and wording must be exact and complete just as indicated so all contestants have a fair chance. The commands may be given in any order and repeated as often as necessary to determine a winner. "()" indicates a choice.

Walk

Trot

Posting trot on the correct diagonal

Lope

Counter Canter

Stop

Back

Sidepass, toward the center of the arena

Sidepass, toward the rail

Stop, dismount, ground tie, leave your animal and go to center of arena

Reverse at a walk and continue walking

Reverse at a walk and trot

Reverse at a trot and walk

Reverse at a trot and continue trotting

Reverse at a lope "(either all at once or at a designated person or location), simple (or flying) lead change, and continue loping in correct lead

Reverse at a lope \*(either all at once or at a designated person or location), no lead change -- counter canter

Hand gallop (designate lead) (no more than 6)

\*\* Beginning with (identify a contestant), and continuing clockwise:

turn on the haunches [head goes required direction] to the (choose direction: right or left) for (choose degree: 360 or 180) degrees

\*\* Beginning with (identify a contestant), and continuing clockwise:

turn on the forehand [head goes required direction] to the (choose direction: right or left) for (choose degree: 360 or 180) degrees

(This designation should be made clear to contestants before the class commences and will result in the same type of reverse as is correct in a driving class.)

\*\* (Judge should first instruct contestants to adjust their position off the rail in order to allow room to complete the maneuver. If contestant fails to allow adequate room, they are faulted out.)

The following list is to be used as a final eliminator and in the following order until a winner is determined. (Worked individually) The first time through the list should be a case of correct or incorrect. If ties have not been broken after that, then the judge may make determinations based on degree of correctness.

1. Simple lead change at cone
2. Posting trot, change of diagonal at cone
3. Lope (or trot) from cone #1 and stop with animal's shoulder at cone #2
4. Flying lead change at cone

## **7.10 Ranch Riding**

A. Ranch riding is a judged event demonstrating the abilities of the animal while working over obstacles found in everyday ranch work. Ranch riding is neither a stunt nor race but should be performed at a reasonable speed. The mule should be judged on the quality of gaits, change of leads and the ability to maneuver over and through the obstacles in a smooth and obedient manner.

1. Credit shall be given and emphasis placed on a cooperative and obedient attitude in the mule as well as smoothness and even cadence of gait. All gaits will be performed as described in western terminology.
2. One hand only allowed on the reins, except for a Green mule shown with a snaffle bit or bosal, and when opening the gate justifies a temporary change of hands.

B. Scoring guidelines are the same as western riding, reining or trail classes when applicable.

C. Penalties: A contestant shall be penalized for: (each instance, as appropriate)

1. Releasing the gate due to the mule's disobedience, unable to complete the gate – 5pts
2. Use of free hand to instill fear in the mule -- 5pts
3. Failure to complete designated lead change – 5pts
4. Refusal at obstacle – 10 pts
5. Blatant disobedience – 5pts
6. **Breaking** of gait at lope – 3pts
7. Knocking down jump – 5pts
8. Hitting or rolling log – 1pt
9. Ticking or light touching of log – ½ pt

D. Disqualification: A contestant is disqualified for going off the pattern. Off pattern is defined as any of the following:

1. Incorrect order of maneuver
2. Knocking over barrels
3. Passing on wrong side of marker or obstacle
4. Missing the jog
5. Knocking over the gate

This Page Intentionally Left Blank

**RANCH RIDING PATTERN:**

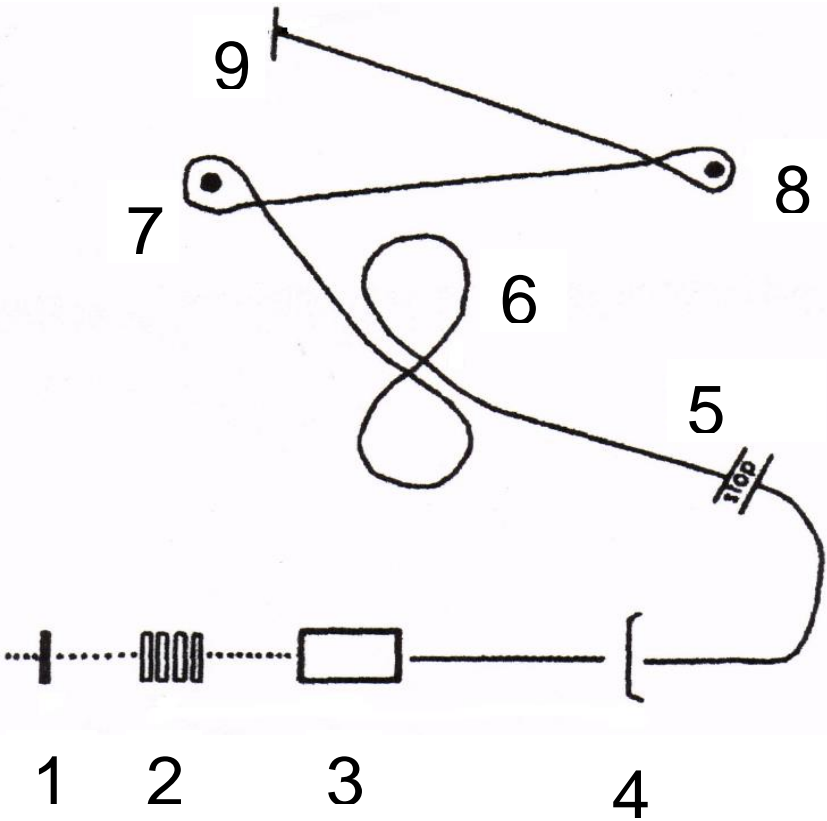

1. Work Gate
2. Walk over logs
3. Walk over bridge
4. Slow lope to and over 12" jump.
5. Stop and perform 2 spins, right or left
6. Proceed at medium lope to figure eight, showing change of lead from right to left circle.
7. Proceed with speed to barrel. Left lead
8. Proceed with speed to barrel. Right lead
9. Slide stop and back 4 steps.

## **VIII. CLASS RULES- ENGLISH PERFORMANCE**

### **8.1 General English Performance Class Rules**

- A. Donkeys and mules may be shown separately or combined. (Exception: although it is NOT recommended to show donkeys and mules in the same class, they may be combined for Novice, English, and Green classes if designated as such on the show flyer.)
- B. Pattern, if applicable, will be posted no less than 1 hour prior to the class itself.
- C. See Section 2.2 for Attire Rules
- D. See Section 3.3 for Equipment Rules

### **8.2 Hunter Under Saddle**

- A. Hunters under saddle should be suitable to purpose. They move with long, low strides reaching forward with ease and smoothness, and should be able to lengthen the stride and cover ground with free flowing movement. Animals should be obedient and have a bright expression with alert ears, and should respond to light leg and hand contact. Animals should be responsive and smooth in transition. When asked to perform the trot or hand gallop, they should move out with flowing motion. The poll should be level with, or slightly above the withers to allow proper impulsion behind. The head should be slightly in front of, or on the vertical.
- B. This class will be judged on performance, condition and conformation. Maximum credit shall be given to the flowing, balanced, willing animal. A maximum 20% of judging shall be based on condition and conformation.
- C. Animals to be:
  - 1. Shown under saddle, not to jump
  - 2. Shown at a walk, trot and canter both ways of the arena. Animals should back easily and stand quietly.
  - 3. Reverse to the inside away from the rail.
- D. Animals may be asked to change to canter from the flat-footed walk

or trot at the judge's discretion.

E. Faults to be scored according to severity:

1. Quick, short or vertical strides
2. Being on wrong lead
3. Breaking gait
4. Excessive speed at any gait
5. Excessive slowness in any gait, loss of forward momentum
6. Failure to take the appropriate gait when it is called for
7. Head carried too high
8. Head carried too low (such that poll is below the withers for five or less strides)
9. Overflexing or straining neck in head carriage so the nose is carried behind the vertical for five or less strides
10. Excessive nosing out
11. Failure to maintain light contact with the animal's mouth
12. Stumbling or falling
13. If animal appears sullen, dull, lethargic, emaciated, drawn or over tired

F. Faults which will be cause for disqualification:

1. Head carried too low (such that poll is below the withers consistently for more than five strides)
2. Overflexing or straining neck in head carriage so the nose is carried behind the vertical consistently for more than five strides.

G. At the option of the judge, all or just the top 12 animals may be required to hand gallop, one or both ways of the arena. Never more than 12 animals to hand gallop at one time. At the hand gallop, the judge may ask the group to halt and stand quietly on a free rein (loosened rein).

### **8.3 Hunter Hack**

A. The hunter hack animal should move in the same style as a working hunter. The class will be judged on style over fences, even hunting pace, flat work, manners and way of going.

B. Animals are first required to jump two fences, two feet to two feet nine inches in height. Exception: donkey hunter hack classes may have jumps 12" to two feet. Donkey jumps may also be of the "X" type  
Jumps do not have to be set on a line. However, if the jumps are set on a

line they must be set 36, 48 or 50 feet apart, or in increments of 12 feet, but no less than 36 feet. A ground line is recommended for each jump.

- C. Animals being considered for an award are then to be shown at a walk, trot and canter both ways of the arena with light contact.
- D. At the discretion of the judge, contestants may be asked to hand gallop, pull up and stand quietly following the last fence.
- E. When necessary to split large classes by running more than one go-round, finalists must both be rejumped and reworked on the flat.
- F. Placing for the class shall be determined by allowing a minimum of 70% for individual fence work and a maximum of 30% for work on the flat.
- G. Faults over fences will be scored as in Working Hunter class. See Rule 8.6 C,D,E. Faults (to be scored accordingly, but not necessarily cause disqualification during the rail work) include:
  - 1. Being on wrong lead
  - 2. Excessive speed (any gait)
  - 3. Excessive slowness (any gait)
  - 4. Breaking gait
  - 5. Failure to take gait when called
  - 6. Head carried too low or too high
  - 7. Nosing out or flexing behind the vertical
  - 8. Opening mouth excessively
  - 9. Stumbling or falling
- H. Exhibitors must be allowed minimum one practice jump prior to start of class
- I. Variation in class may be "Donkey Working Hunter". Animals to jump a minimum of 4 obstacles / 4 fences. One change of direction is mandatory. Height of jumps to be 8" to 24" and height should be stated on show flyer.

## **8.4 Hunt Seat Equitation**

- A. General: The hunt seat equitation class is to determine the riding ability of the rider. Rider should have a workmanlike appearance, seat and hands light and supple, conveying the impression of complete control should any emergency arise.
- B. Basic Position:

1. To mount, take up reins in left hand and place hand on wither. Grasp stirrup leather with right hand and insert left foot in stirrup and mount. To dismount, rider may either step down or slide down. The size of rider must be taken into consideration.
  2. Hands should be over and in front of animal's withers, knuckles thirty degrees inside the vertical, hands slightly apart and making a straight line from animal's mouth to rider's elbow. Method of holding reins is optional, and bight of reins may fall on either side. However, all reins must be picked up at the same time.
  3. The eyes should be up and shoulders back. Toes should be at an angle best suited to rider's conformation; heels down, calf of leg in contact with animal. Iron should be on the ball of the foot and must not be tied to the girth.
  4. At the walk, sitting trot and canter, body should be vertical; posting trot, inclined forward; galloping and jumping, same inclination as posting trot.
- C. Class Routine: Each rider will work individually. Individual works may be comprised of any of the following:
1. Back
  2. Gallop and pull up
  3. Figure 8 at trot, demonstrating change of diagonals. At left diagonal, rider should be sitting the saddle when left front leg is on the ground; at right diagonal rider should be sitting the saddle when right front leg is on the ground; when circling clockwise at a trot, rider should be on left diagonal; when circling counter-clockwise, rider should be on right diagonal
  4. Figure 8 at canter on correct lead demonstrating simple change of lead. (This is a change whereby the animal is brought back into a walk or trot and restarted into a canter on the opposite lead.) Figures to be commenced in center of two circles so that one change of lead is shown
  5. Ride without stirrups
  6. Dismount and mount
  7. Figure 8 at canter on correct lead, demonstrating flying change of lead
  8. Change of leads down center of arena demonstrating simple lead change
  9. Execute serpentine at trot and/or canter on correct lead demonstrating simple or flying changes of lead. A series of left and right half circles off center of imaginary line where correct diagonal or lead change must be shown
  10. Canter on the counter lead
  11. Half turn or full turn on forehand and/or a half turn or full turn on

the haunches. (See diagram after Trail Class)

D. The judge will use individual works to determine the top riders to be called back for rail work. Selected riders will be required to work the rail.

### **8.5 English Pleasure** (AHSA Description, Actually A SADDLE SEAT CLASS. USE HUNTER UNDER SADDLE UNLESS EXHIBITORS IN YOUR AREA ARE OUTFITTED FOR THIS CLASS.)

A. Competitors enter the ring at a normal trot and will be shown at a walk, normal trot, strong trot, canter and hand gallop. Light contact must be maintained with all reins at all gaits. A judge may not request that gaits be performed only on the snaffle or curb.

B. It is imperative that the animal give the distinct appearance of being a pleasure to ride and display a pleasurable attitude. To this end, all gaits must be performed with willingness and obvious ease, cadence, balance and smoothness

1. Walk: Four beat, brisk, true and flat-footed with good reach.
2. Normal trot, a 2-beat gait: To be performed at medium speed with moderate collection. The normal trot must be mannerly, cadenced, balanced and free moving. Posting is required.
3. Strong trot, a 2-beat gait: This trot is faster and stronger than the normal trot. It is performed with a lengthened stride, powerful and reaching at a rate of speed which may vary between animals since each animal should attain his own strong trot in harmony with his own maximum natural stride. The animal must not be strung out behind. It should show moderate collection without exaggeratedly high action in front. It must present a willing attitude while maintaining form. The strong trot must be mannerly, cadenced, balanced and free moving. Posting is required.
4. Canter, a 3-beat gait: Smooth, unhurried, with moderate collection, correct and straight on both leads.
5. Hand Gallop: The hand gallop is performed with long free ground covering stride under control. The amount of ground covered may vary between mules due to the difference in natural length of stride. The hand gallop is not a fast collected canter but a true lengthening of stride, correct and straight on both leads. Extreme speed to be penalized.

## 8.6 Working Hunter

A. A Hunter course shall be any course which management deems a fair test of a hunter, but judges are responsible for correctness of each course after it has been set and shall call the show committee's attention to any errors that would tend to result in unfair or inappropriate courses.

B. Course or Arena Arrangement:

1. Minimum of 4 obstacles. Animals to jump a minimum of 8 fences. One change of direction is mandatory.
2. Types of obstacles which may be used:
  - a. Fences shall simulate obstacles found in the hunting field, such as natural looking post and rail, brush, walls, coops and ascending oxers (not square). Triple bar and hogsback are prohibited. Striped poles are not recommended.
  - b. The top element of all fences must be securely placed so that a slight rub will not cause a knockdown.
  - c. Distance between fences is recommended to be in 12-foot increments with the exception of some combinations: 1 stride in and out, 24-26 feet; 2 strides in and out, 36 feet; 3 strides, 48 feet.
  - d. Heights:

Green	2'9" to 3'
Open	3' to 3'6"
  - e. A variation of 3 inches in fence height, down from official heights listed, may be instituted if show management and the official judges feel circumstances warrant, i.e., footing, weather, etc.
  - f. The use of wings on obstacles in hunter classes is recommended.
  - g. Jump standards with hole heights at 3-inch intervals with jumps cups are recommended.

C. Scoring:

1. To be judged on manners, way of going and style of jumping. Mules shall be credited with maintaining an even hunting pace that covers the course with free-flowing strides, preference will be shown to mules with correct jumping style that fences squarely, jumping at the center of fence. Judges penalize unsafe jumping and bad form over fence, whether touched or untouched, including twisting. Incorrect leads around ends of the course or cross-cantering shall be penalized, as is excessive use of crop. In and outs (1 or 2 strides) shall be taken in the correct number of strides or be penalized. Any error which endangers the mule and/or its rider, particularly refusals or knockdowns, shall be heavily penalized.

2. Scoring shall be on a basis of 0-100, with an approximate breakdown as follows:
  - 90-100: an excellent performer and good mover that covers the entire course with cadence, balance and style
  - 80-89: a good performer that jumps all fences reasonably well; an excellent performer that commits one or two minor faults
  - 70-79: the average, fair mover that makes no serious faults, but lacks the style, cadence and good balance of the scopier mules; the good performer that makes a few minor faults
  - 60-69: poor movers that make minor mistakes; fair or average movers that have one or two poor fences but no major faults or disobediences
  - 50-59: a mule that commits one major fault, such as a hind knockdown, refusal, trot, cross canter or drops a leg
  - 30-49: a mule that commits two or more major faults, including front knockdowns and refusals, or jumps in a manner that otherwise endangers the mule and/or rider
  - 10-29: a mule that avoids elimination but jumps in such an unsafe and dangerous manner as to preclude a higher score.

D. Elimination:

1. A total of three disobediences which can include any of the following: refusal, stop, runout, or extra circle
2. Jumping an obstacle before it is reset
3. Bolting from the arena
4. Off course
5. Deliberately addressing an obstacle
6. Animal and/or rider falling. Animal is considered to have fallen when shoulder and haunch on the same side touch the ground, or the obstacle and the ground.

E. General:

1. Circling once upon entering the ring and once upon leaving is permissible.
2. After jumping the fence and prior to leaving the arena, the animal shall trot a small circle on a loose rein for soundness.
3. Animals shall not be requested to re-jump the course.
4. Manners shall be emphasized.
5. When an obstacle is composed of several elements, any disturbance of these elements will be penalized; however, only a reduction in height of the top element shall be considered a knockdown.
6. In cases of broken equipment, the rider may either continue without

penalty, or stop and correct the difficulty and be penalized the same as any loss of forward impulsion.

7. When an obstacle requires two or more fences (in and out), faults committed at each obstacle are considered separately. In case of a refusal or run-out at one element, entry may re-jump the previous elements.
8. Disobediences (major faults) - see Jumping Rules VIII 8.7 E 2.
9. The course must be posted at least one hour before scheduled time of class.
10. Whenever possible, a schooling area should be provided with at least one practice jump.
11. Schooling over obstacles in the ring or over any part of any outside course is permitted only at the time designated by show management.

## **8.7 Jumping**

A. Arena Arrangement:

1. There will be a minimum of four obstacles; animals are to make a minimum of eight jumps.
2. A spread fence consisting of two or more elements will be mandatory.
3. It is recommended the first obstacle be no more than minimum height.
4. Optional obstacles may include:
  - a. Post and Rail (at least two)
  - b. Chicken Coop
  - c. Stone Wall
  - d. Triple Bar
  - e. Brush Jump
5. Both a starting line at least 12 feet in front of the first obstacle, and a finish line at least 24 feet beyond the last obstacle must be indicated by markers (at least 12 feet apart) at each end of the lines. Animal must start and finish by passing between markers.
6. Obstacles, except within combinations, should be seated a minimum distance of 48 feet apart, size of arena permitting.
7. Height of obstacles must be a minimum of three feet except in Green

which is a minimum of two feet nine inches.

B. Jump-offs will be held over the original course altered as outlined. In a jump-off, the sequence of obstacles may be in any order as long as the original direction is maintained. Only in the case of clean round ties, for first place or when points are involved, the height and spread of at least 50 percent of the obstacles shall be increased not less than three and not more than six inches in height, and to a maximum spread of six feet. In case of ties involving faults, rails shall not be raised, courses may be shortened after the first round. However, the course may not be shortened to less than 40 percent of the original obstacles and must include at least one vertical and one spread jump. When a jump-off is required, the winner will be decided on time only if faults are equal. If two or more animals are disqualified in the timed jump-off and are tied for a point, they are not to be re-jumped, but should flip a coin to break the tie.

C. Time shall begin from the instant the animal's chest reaches the starting line until it reaches the finish line. Time shall be stopped while a knocked down jump is being replaced, this is from the moment the rider gets his mount in a position to retake the jump until the proper authority signals that the jump has been replaced. It shall be the rider's responsibility to be ready to continue the course when the signal is given.

D. Scoring: Jumpers are scored on a mathematical basis and penalty faults, which include knockdowns, disobediences and falls.

1. Knockdown: An obstacle is considered knocked down and four faults assessed, when an animal or rider, by contact:

a. Lowers any part thereof which establishes the height of the obstacle or the height of any element of a spread obstacle even when the falling part is arrested in its fall by any portion of the obstacle; or

b. Moves any part thereof which establishes the height of the obstacle so it rests on a different support from the one on which it was originally placed;

c. Knocks down an obstacle, standard, wing, automatic timing equipment or other designated markers on start and finish lines.

d. If an obstacle falls after the animal leaves the ring, it shall not be considered a knockdown.

2. Disobediences:

a. Refusal: When an animal stops in front of an obstacle (whether or not the obstacle is knocked down or altered) it is a refusal unless the animal then immediately jumps the obstacle without backing one step. If animal takes one step backwards, it is a refusal.

(1) After a refusal, if an animal is moved toward the obstacle but does not attempt to jump, it is considered another refusal.

(2) In the case of a refusal on an in-and-out jump, the animal must return to the start of the in-and-out sequence and rejump previous elements as well as following elements.

b. Run-out: A run-out occurs when the animal evades or passes the obstacle to be jumped; jumps an obstacle outside its limiting markers; or when the animal or rider knocks down a flag, standard, wing or other element limiting the obstacle (without obstacle being jumped).

c. Loss of forward movement: Failure to maintain trot, canter or gallop after crossing starting line, except when it is a refusal, a run-out or when due to uncontrollable circumstances, such as when an obstacle is being reset.

d. Unnecessary circling on course: Any form of circle or circles, whereby the animal crosses its original track between two consecutive obstacles anywhere on course, except to retake obstacle after refusal or run-out.

e. First disobedience anywhere on course - 3 faults.

f. Second cumulative disobedience anywhere on course - 6 faults.

### 3. Elimination

a. Third cumulative disobedience anywhere on course.

b. Fall of animal and/or rider.

c. Jumping an obstacle before it is reset, or without waiting for signal to proceed.

d. Starting before judges signal to proceed.

e. Failure to enter ring within one minute of being called.

f. Failure to cross the starting line within one minute after an audible

signal to proceed.

g. Jumping an obstacle before crossing start line if said obstacle is designated as a practice obstacle, or crossing the finish line, whether forming part of the course or not.

h. Off course.

i. Deliberately addressing an obstacle (penalized any time the animal is in the ring).

j. Rider and/or animal leaving the arena before finish-course (penalized at any time the animal is in the ring).

4. In cases of broken equipment, the rider may either continue without penalty or stop and correct difficulty, in which will be penalized three faults. In case of loss of shoe, rider may either continue without penalty or be eliminated.

# JUMPS

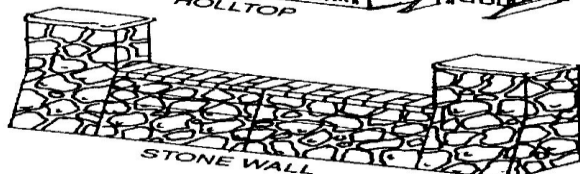
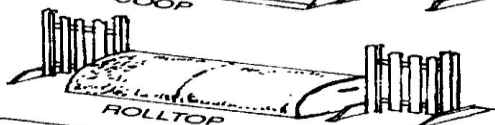

Hunter fences are supposed to simulate the type of fences found in the hunt field in the course of a foxhunt. Rails should be natural wood in color or painted white. Pickets and gates are usually painted white. Rolltops and brush boxes are usually painted green to simulate grass and foliage. Small boxes or panels may be painted to simulate stone or brick walls.

In the show ring the fences should be at least 20 feet wide (the distance between the wings) with wings 30 inches wide and at least 12 inches taller than the top rail of an obstacle.

Jumper fences are usually painted with bright colors. Obstacles without groundlines are permitted.

An "in and out" consists of two fences one or two strides apart, a stride being approximately 12 feet. A combination consists of "two, three or more obstacles with a maximum inner distance between them of 39 feet 5 inches which must be taken in two, three or more successive jumps". (AHSA Rules)

This Page Intentionally Left Blank

# **IX. CLASS RULES – SPECIALTY PERFORMANCE CLASSES**

## **9.1 General Specialty Class Rules**

- A. Classes in this division may not count toward a Western Performance Division but may count toward an overall highpoint award, or be considered for points within some special division for special awards or may be used as a jackpot class (to be designated on show flyer).
- B. Attire and equipment will be specific to each class if noted; if not, then normal western attire (Section 2.1) and equipment (Sections 3.2) will be required.
- C. Additional Specialty Classes may be added by show management but rules must either be on the show flyer or posted at the show prior to entry deadline.

## **9.2 Coon Hunters Jumping**

- A. Open to both donkeys and mules. Open to Adult and Youth age exhibitors but any Youth exhibitor must have a responsible adult **assistant** in the ring during the class. This sponsor" may not physically assist except in cases of uncontrollable circumstances, and any assistance will terminate further competition from that Youth exhibitor. Youth will not be allowed to exhibit jacks.
- B. Attire: Western attire or anything that a real coon hunter might wear except no tennis shoes. Some type of hat or cap required.
- C. Equipment: (Recommended jump specifications.) Free standing jump will have a single, vertical freely sliding cross-bar which will be supported by wood dowel pins no more than **1/4"** in diameter which will break and drop the crossbar if the animal fails to make the jump. Horizontal width of jump will be minimum of 8 feet. Holes for dowel pins can be at 2 inch increments with the bottom hole 30 inches from the ground, and the top hole at 72 inches.
- D. May have separate classes for animals up to 48" and 48.01 " and over.
- E. Animals to 48" will jump from inside a 10 foot marked box. animals 48.01 " and over will jump from inside a 12 foot marked box. The box

can be marked with chalk, paint or a line drawn in dirt, but may NOT be marked with rope or string.

F. Initial jump will be determined by the median chest height of the smallest and largest animals in the class.

G. Initial jump must be cleared to qualify for placing.

H. Each attempt to be timed by stopwatch, with a required backup stopwatch. Time starts when the first hoof touches ground in box.

I. Two attempts may be made at each height in a maximum of 90 seconds. Time is stopped only to replace pins.

J. After entering marked box area, animal must stop completely before jumping. "Stop" is defined as cessation of all forward motion, all four feet on ground at same time. Failure to stop will be counted as one attempt.

K. If animal steps out of the marked box, it will be considered an attempt.

L. Handler may stand to either side of box, but must hold reins or lead rope in hands at all times.

M. A blanket or cover may be used over the jump if the handler desires (and provides).

N. No physical force or abuse will be allowed.

O. Animal may lean against jump, but may not push jump more than two feet or it is considered an attempt. ;

P. Should two or more animals tie for a height, the animal which clears the jump in one attempt will be the winner, regardless of time. If both animals clear the jump on the same attempt (first or second), the animal with the fastest time will be the winner.

### **9.3 Costume Class**

A. Donkeys and mules may show in the same class. Jacks may be excluded at show management's discretion (exclusion to be noted on show flyer and also excludes this class from counting toward overall High Point Donkey)

- B. Animals must be shown in some costume that is authentic in some country, work of literature or art, or in some occupation or sport, past or present.
- C. Costume to be judged on originality, authenticity and audience appeal.
- D. Each entry in this class MUST be accompanied by a typed or legibly written description to be read by the announcer. It is suggested that show management place a time limit of two minutes on each entry's entire costume presentation. If a time limit is chosen, it must be stated on the entry information so contestants can have time to correctly prepare their presentation. Show management must also be sure to have a time keeper available to keep track of each entry's time. Failure to adhere to any stated time limit will remove that entry from award consideration.
- E. The written description and any taped music should be given to the show representative at a time specified in the show flyer or announced at the show so management will have time to read and assemble the information to exhibitor's best interest. Since no costume information will be taken after the appointed time, the exhibitor may elect to show without script/tapes or withdraw from the class with no refund of entry fee(s).
- F. Any number of people or props may be used to make up a costume, however, all participants must be in related costume.
- G. Open to all age exhibitors.

## **9.4 Freestyle Reining**

- A. Required maneuvers
  1. 4 right spins
  2. 4 left spins (spins need not be consecutive)
  3. 2 stops
  4. 2 lead changes
- B. Costume optional
- C. Music required - at least one minute, but under four minutes
- D. Rider may ride two handed with any approved bit.

# 9.5 Side Saddle

## CORRECT POSITION



## CORRECT LEG POSITION

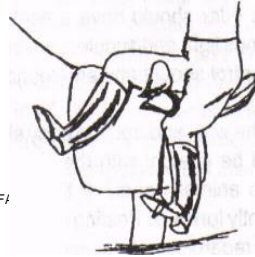

RIGHT LEG  
EXTENDED TOO F/  
FORWARD

## BASIC MISTAKES

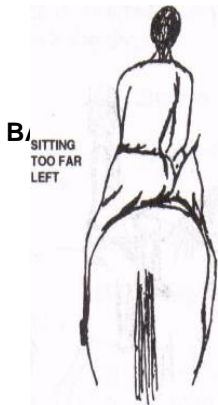

B,  
SITTING  
TOO FAR  
LEFT



LEANING TO  
THE LEFT,  
AND TRYING  
TO KEEP  
SHOULDERS  
STRAIGHT

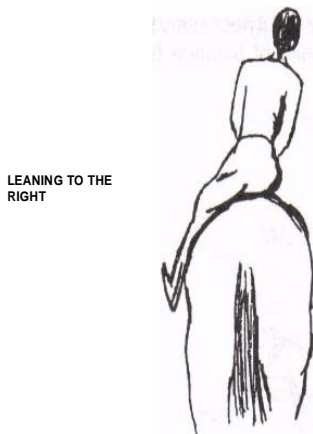

LEANING TO THE  
RIGHT



SITTING  
TOO FAR  
RIGHT

## **X. CLASS RULES - SPEED EVENTS**

### **10.1 General Speed Event Rules**

- A. Separate classes for donkeys and mules.
- B. Two timers will be used. A time light will be used (when available) as first timing device and a stop watch will be used as back up. When there is a significant amount of difference between the two (3 seconds), a rerun should be given.
- C. See Section 2.1 for Attire Rules.
- D. See Section 3.4 for Equipment Rules.
- E. Any unsportsmanlike conduct or animal abuse will be cause for a disqualification.
- F. Classes involving tethered live animals are prohibited.
- G. Riders may not start their run until the gate is closed. Gate will remain closed until run is over.
- H. Ties will be broken with a run-off.
- I. In any of the timed classes, a contestant will have no more than 1 minute to cross the starting line or engage the first obstacle before being disqualified.

### **10.2 Straight-Away Barrels**

- A. Pattern will be 3 barrels in a straight line. Suggested pattern dimensions: 21 feet from start/finish line, then:
  - 1. Donkeys - 21 feet to each barrel
  - 2. Mules - 60 feet to each barrel
- B. First barrel may be started from either side.
- C. Contestant allowed a running start (within arena).

- D. No penalty for touching or resetting a barrel.
- E. A 5 second penalty will be added for each barrel knocked over.
- F. Breaking pattern a disqualification.

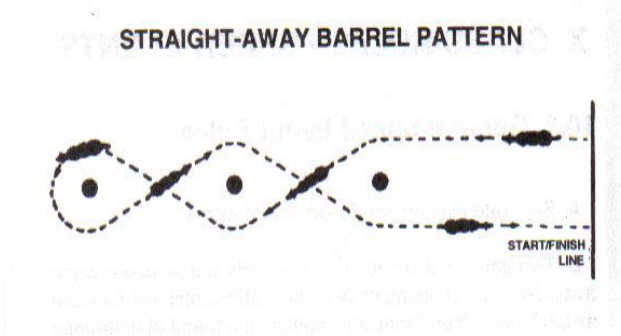

### 10.3 Cloverleaf Barrels

- A. Standard pattern shall consist of 3 barrels spaced in a triangle and sized to safely fit arena. Start/Finish line should be minimum of 45 feet from end of arena.
- B. Pattern may be run from left or right side.
- C. Contestant allowed a running start (within arena).
- D. No penalty for touching or resetting a barrel.
- E. A 5 second penalty will be added for each barrel knocked over.
- F. Breaking pattern a disqualification.

## CLOVERLEAF BARREL PATTERN

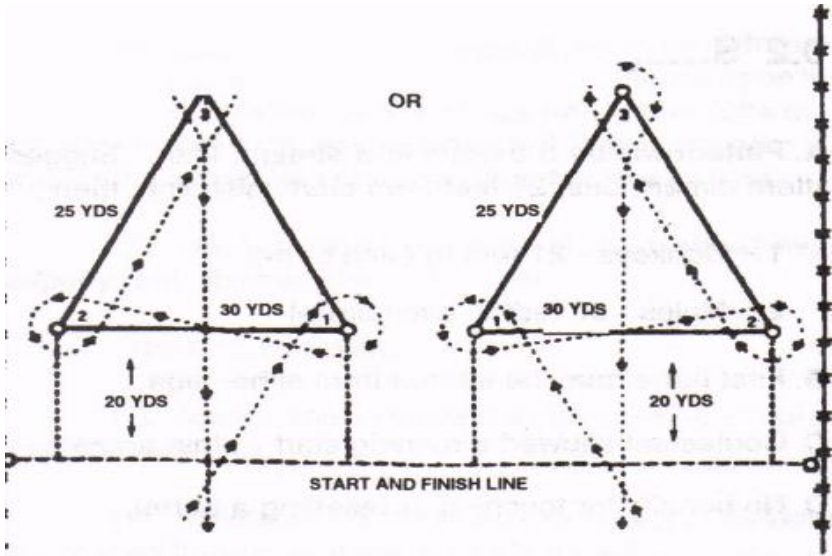

### 10.4 Pole Bending

- A. Contestant allowed a running start within arena.
- B. The pattern is to be run around 6 poles set in a straight line. Poles should be 21 feet apart and at least 21 feet from the starting line. Poles shall be set on top of the ground, 6 feet height with a base no more than 14 feet in diameter.
- C. Pattern may start either to the right or left of the first pole.
- D. Contestant will run to the far end of the line of poles before starting to weave the poles back toward the start, turn and weave the poles back to far end, then run to finish line.
- E. Knocking over a pole will carry a 5 second penalty.
- F. Rider may touch a pole with no penalty.
- G. Breaking pattern will result in disqualification.
- H. Breaking the time line on the return pass shall be a disqualification.

# POLE BENDING PATTERN

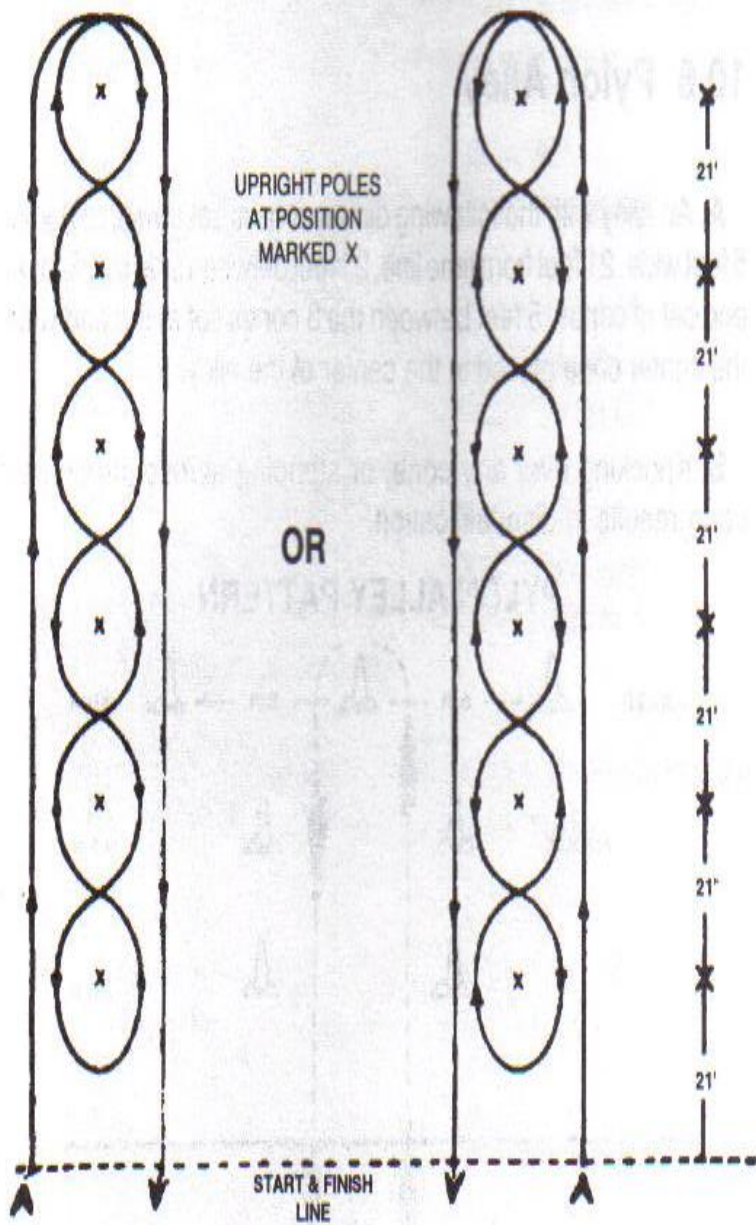

## 10.5 Keyhole Race

- A. A keyhole with the following dimensions is drawn on the ground with white lime: 4 foot wide, 10 foot long lane opening into a 20 foot circle. The throat of the keyhole will be perpendicular to and facing the timing line. The center of the circle of the keyhole will be 150 feet from the timing line. The length of the timing line will be 90 feet.
- B. Contestant crosses timing line, enters lane, turns animal around in keyhole circle in either direction, and returns back down the lane and across the timing line.
- C. Stepping on or out of any of the lines results in disqualification. All limed lines must be kept visible for all entries.
- D. There should be at least 3 line judges

### KEYHOLE PATTERN

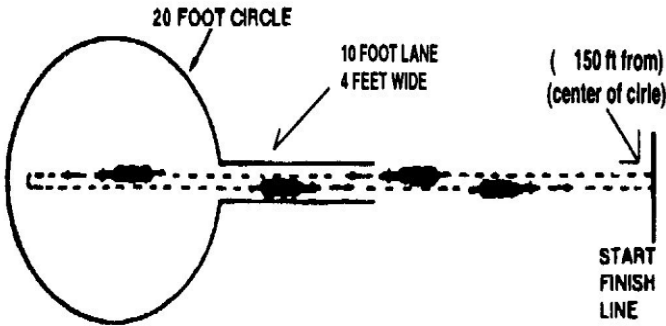

## 10.6 Pylon Alley

- A. An alley with the following dimensions is set up with pylons 5 feet wide, 21 feet from time line, 21 feet between side cones and end set of cones, 5 feet between the 3 cones set at the end with the center cone placed in the center of the alley.
- B. Knocking over any cone, or stepping across the center cone results in disqualification.

## PYLON ALLEY PATTERN

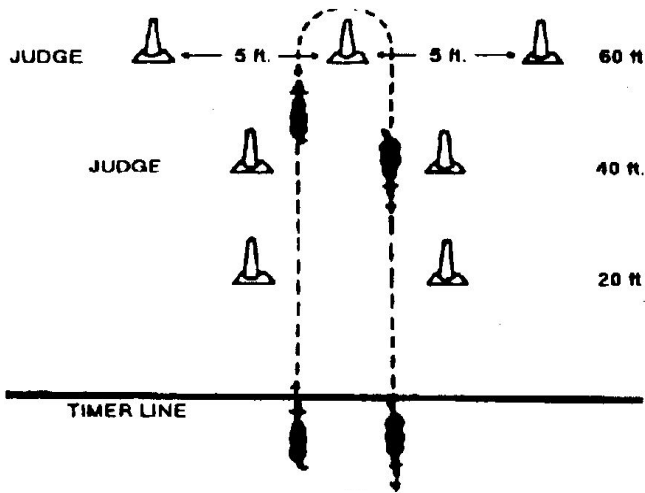

### 10.7 Potato Race (Baseball Race)

- A. Standard pattern: 55 gallon drum placed 152 feet from the time line. A 30 gallon open barrel located 20 feet from the time line.
- B. Potatoes (baseballs) can be placed in a bucket of sand on top of the 55 gallon drum, or if there are Youth contestants on small donkeys, the potatoes (baseballs) can simply be placed on top of the drum itself. Every contestant should have the same number of potatoes (baseballs) from which to choose.
- C. The contestant may start on either side of the first barrel, sprints to the far barrel, rounds it and picks up the potato and attempts to put it in the shorter barrel as he races toward the finish line.
- D. Circling either barrel, making a figure 8 around the barrels, dropping the potato or missing the smaller barrel results in disqualification.
- E. Variation: (Speared potatoes) A two foot square frame containing about 15 potatoes is placed 180 feet from the time line. Spear is 5 feet long, made from wood or metal, and has a steel point about three inches long. Potato can be re-speared if dropped before crossing time

line, but rider may not dismount. Animal stepping into potato frame or circling the frame results in disqualification.

## **10.8 Flag Race**

A. Procedure options listed below:

1. 3-Flags: Rider carries a flag across the time line to the first flag bucket, changes flags, goes around the barrel to the second bucket, changes flags, and continues across time line.
2. 2-Flags: Rider picks up flag from one bucket and changes flags at the second bucket.
3. 1-Flag: Rider picks up flag from one bucket and places it in second bucket.

B. Two three-gallon buckets filled with sand are used, either sitting on top of a 55 gallon drum or attached to the arena fence. Flags can be 6" x 8" on a 14" stick, or triangular on an 18" stick, and should be different colors.

C. Contestant may start from right or left of pattern.

D. Knocking over a turn barrel carries a 2 second penalty.

E. Disqualifications:

1. Running pattern incorrectly
2. Circling a barrel
3. Hitting animal with the flag
4. Failure to stab flag in pail so that it stands (not supported by edge of bucket)

## **10.9 Egg Race**

A. Contestant rides to barrel at opposite end of arena, pick up an egg, places it in his/her mouth and returns across the time line.

B. Disqualifications:

1. Circling the barrel
2. Knocking over the barrel
3. Breaking the egg

## **10.10 Egg In Spoon Ride**

A. All contestants will be in the arena at the same time, and each will be given a spoon and one raw egg. While holding the spoon only, riders are asked to walk, trot, and lope. The last rider carrying an egg will be the winner.

## **10.11 Ride A Buck**

A. Rider provides own dollar which is placed between the rider and the saddle about halfway between the knee and the hip joint. The dollar will extend out from behind the leg visible to the Judge (about half a buck).

B. All contestants (in the arena at the same time) will be asked to walk, trot and lope or the judge may call for other maneuvers in order to determine a winner. The winner will be the last person to still have a dollar under their leg.

C. At no time can the rider touch or replace the dollar with his/her hand.

D. All dollars that are dropped in the arena will be awarded to the winner.

E. Class may be done with or without a saddle but must be designated on show flyer.

## **10.12 Hurdle Race**

A. Pattern consists of 3 jumps no higher than 2'6" set according to size of the arena.

B. Contestant enters arena dismounted and jumps first jump in that manner. Rider may jump with animal or go around. Rider then mounts and jumps next two jumps and crosses time line.

C. Style of jumping or touches do not count. Knock downs are penalized 5 seconds.

D. Purposely knocking down jumps results in disqualification.

## **10.13 Tunnel Race**

A. Rider races to an open ended barrel at the opposite end of the arena,

dismounts, crawls through barrel, then remounts to race back across time line.

- B. Rider may ground tie or leave reins up on saddle but may not tie the animal to any object or have reins or lead that is longer than 7 feet. Carrying a line of any type into barrel results in disqualification.
- C. Rider must catch and mount animal before crossing time line. Animal's crossing of time line without rider results in disqualification.

### **10.14 Hide Drag**

- A. Team consists of an adult rider and a "dragee" who is waiting behind a line or barrel at the opposite end of the arena.
- B. Rider dallies hide rope to saddle horn, races around barrel at opposite end of arena, "dragee" jumps on hide anywhere behind the barrel and team proceeds back across the finish line.
- C. Time stops when rider crosses finish line, however, "dragee" must still be on (or under, as long as holding some part of hide or rope) the hide until it crosses the line for time to qualify.
- D. If "dragee" misses the hide or falls off before rider crosses the finish line, the rider may circle the barrel again to give him another opportunity to reload. Rider may continue to circle the barrel until successful.
- E. Crossing the finish line before a correct "load" from behind the barrel will disqualify.
- F. Western attire not required for "dragee". Suitable attire could include a coverall and gloves. **Some type of protective head gear is required.**
- G. "Dragee" must be 11 years of age (by January 1 of current year) or older.

### **10.15 Boot Race**

- A. Contestants remove their boots and the boots are placed in a pile at the opposite end of the arena. Boots may not be marked with any type of paper, rope or ribbon. They may be of an unusual color.

B. On signal riders will:

1. Either ride or lead animals to boots (as designated by management)
2. Find their own, put them on their feet, mount and race to time line

### **10.16 Sack Race**

- A. Riders will race to the opposite end of the arena where there will be a pile of tow sacks. Rider dismounts, puts both feet in this sack and returns to the start/finish line leading animal.
- B. All forward progress must be with both feet in the sack
- C. No leads or reins longer than 7 feet shall be used to lead the animal.
- D. First person to cross finish line leading their animal wins. (Animal does not actually have to be across line but must be "in hand".)

### **10.17 Old Clothes Race**

- A. Race is best run with two contestants to a heat but may be run one at a time. Contestants are timed individually.
- B. Contestant(s) will ride to the opposite end of the arena where there will be a pile or container of clothes.
- C. Contestant(s) will dismount and put on whatever is found in the pile or container. The clothes must be worn as intended. Buttons and zippers need not be closed as long as the garment stays on as intended.
- D. Contestant will then remount and ride to the finish line.
- E. Clothes will be replaced in the same form for each contestant.
- F. Variation: Team to consist of 2 people and 1 animal, first rider puts on, rides back to start, takes off and other rider puts on, rides back to container, takes off and replace in container, closes container, and races back to time line. Best done heads up and just for fun -- teams matched for age and skill levels and degree of dishonesty.

## **10.18 Rescue Race**

- A. Rescuer will be mounted, ride to opposite end of arena where "rescuee" will be waiting behind a marker (pylon, barrel or line), pick up the "rescuee" and ride double back across the finish line.
- B. "Rescuee" must be off the ground when crossing the finish line.
- C. No ropes or other pieces of added equipment will be allowed.
- D. "Rescuee" must be 11 years or older by January 1st of current year.

## **10. 19 Stake Race**

- A. Timing shall begin as soon as the animal's nose reaches the starting line and will be stopped when the animal's nose passes over the finish line.
- B. The contestant is allowed a running start (inside the arena) and may begin the run from either the left or right side of the first pole. Start by crossing the center line between the upright markers, turn around the second pole, cross over the center line again between the markers, then around the first pole and run back across the finish line.
- C. The start and finish line is 20 feet wide and marked by two upright markers (10 feet on each side of the center line and short enough so as to not interfere with the timer if one is used. Short pylons or cones are recommended.) The first and second poles marking the center line are each 40 feet from the start and finish line, making them a total of 80 feet apart.
- D. Disqualifications:
  - 1. Failure to cross the start and finish line between the markers
  - 2. Failure to cross over the center line between the markers before turning the second pole and/or failure to cross back over the center line after turning the second pole
  - 3. Knocking down an upright marker or pole

## STAKE RACE PATTERN

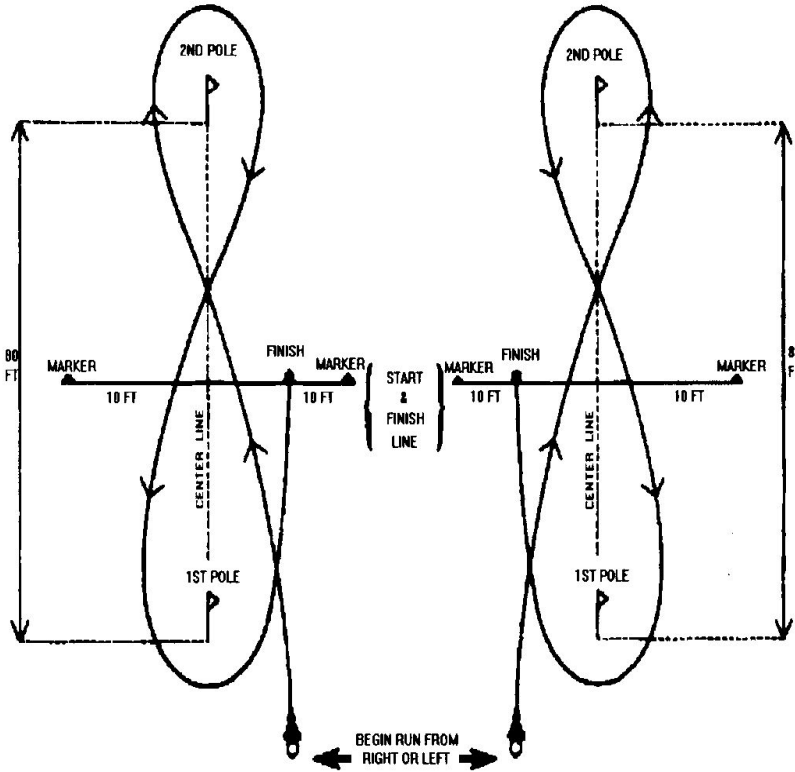

### 10.20 Run, Ride and Lead

- A. Entry will be one rider and one animal, however, it will be necessary to have a holder for each animal.
- B. Race starts on foot at opposite end of arena from animals. Contestant runs to animal, mounts (assistance allowed), rides back to line at opposite end of arena, dismounts and leads animal back across line at other end.

### 10.21 Gambler's Choice Trail

- A. An assortment of trail obstacles will be placed in the arena with various point values depending on the degree of difficulty and distance from the time line. Contestant attempts to garner as many points as

possible by successfully completing obstacles during the time limit.

B. Suggested time limit for this class is two minutes, but show management may choose any other time as long as it is posted prior to the class.

C. An obstacle can ONLY BE REPEATED TWICE, but not until one other obstacle has been successfully completed.

D. If an obstacle is disturbed, points for that obstacle will not count and contestant may not attempt that obstacle again.

E. If a contestant is committed to an obstacle at the time limit, and completes it successfully, the points will count. Judge to determine commitment.

F. Maximum speed between obstacles must be posted. It is suggested that the maximum speed in Youth classes be a trot. If the limitation is a trot, the following applies:

1. The first occurrence of loping (4 strides or less) will result in a 5 point penalty; the second occurrence will result in disqualification.
2. Loping more than 4 strides will result in disqualification

G. Pattern

1. Must state value of each obstacle. (Basic values for each obstacle based on their average completion times are listed on the sample Tally Sheet {next pg}, additional points can be added based upon the obstacle distance from the starting line and from other obstacles.)
2. Must indicate correct route through obstacle, (i.e Bridge - indicate using dashes that it should be crossed the long way to keep someone from saving time and crossing the shorter side.)
3. Unless pattern states that an obstacle can only be worked from one direction (by using arrows instead of dashes and including the word "only" next to the obstacle), it will be assumed that any obstacle can be worked from either direction following the dashes.

H. Obstacles

1. Generally should be workable from either direction however, if this is not so, then pattern should indicate.
2. Should be completed in the usual way as would be done in a regular trail class except that since there is no judging, rules like losing hold of the gate would not matter as long as you opened, went through and

closed the gate without "disturbing" it.

3. Some obstacles might require show management to define "successfully completed", such as the following suggestions:
  - a. Slicker - both arms must be placed in, then removed and replaced
  - b. Water Box - both front feet must be placed in box then if animal jumps straight over, exiting box on side opposite entry it will count even if back feet never landed in box

#### I. Workers needed in addition to the judge and announcer

1. Equipment Assistants - At least 4 people in arena to assist the judge if requested to indicate if obstacle has been "disturbed" and to reset obstacles.
2. Scribe (or Ring steward) - Use tally form similar to sample which follows.
  - a. Notations could be made in box above "X" for unsuccessful attempts (i.e. "1 arm" if slicker only put on 1 arm).
  - b. A notation could be made in the box for the last obstacle if a decision had to be made by the judge if contestant was committed to it or not.
3. Timers (use announcer as one) NOTE: (rules state there must always be a backup timer).
  - a. Contestant must start at a designated point, inside the arena, from a standstill.
  - b. Announcer should ask each contestant if they are ready before saying "Go", and call "Time" at the designate time.

#### J. Definitions:

1. Successfully completed - obstacle has been negotiated correctly according to normal Trail Class maneuvers (except 1 hand on gate) in the correct direction as indicated on the pattern without disturbing any of the elements which are part of the obstacle.
2. Disturb - to move or rearrange an obstacle in such manner that it is in any way different from its original condition before attempted. An obstacle which has been touched in any way, then returns to its original position by the time the animal has completed the obstacle is not disturbed.
3. Committed - When "time" has been called, if any part the animal's body is across the plane of any part of an obstacle going in the correct direction and in a manner which would allow it to be successfully negotiated, then the contestant is committed to that obstacle. It is the judge's uncontestable decision to rule on whether a contestant is committed.

# SAMPLE TALLY SHEET

CLASS NUMBER: \_\_\_\_\_

GAMBLER'S CHOICE TRAIL

SCORE CARD

Exhibitor # \_\_\_\_\_

OBSTACLE	RECORD OF ALL ATTEMPTS (Either ✓ or X)					TALLY of ✓'s Only	X	OBSTACLE POINT VALUE	SUB- TOTALS
Back Thru							X	10	
Box - 360							X	10	
Bridge							X	5	
Can Carry							X	15	
Cone Back Thru							X	40	
Gate							X	40	
Mailbox							X	10	
Sidepass							X	10	
Slicker							X	30	
Tarp							X	5	
Walkover							X	5	
Water Box							X	50	
TOTAL SCORE									

All obstacles may be worked either direction as indicated by " \_ " Speed Limited to TROT. (Lope over 1 stride disqualified.)

COMMENTS:

# **XI. CLASS RULES - CATTLE CLASSES**

## **11.1 General Cattle Class Rules**

- A. Separate classes for donkeys and mules.
- B. In timed classes, two timers will be used. A time light will be used (if available) as first timing device and a stop watch will be used as back up. When there is a significant amount of difference between the two (3 seconds), a rerun should be given.
- C. See Section 2.1 for Attire Rules.
- D. See Section 3.4 for Equipment Rules.
- E. Any unsportsmanlike conduct or animal abuse will be cause for disqualification.
- F. Ties will be broken with additional steers until tie is resolved.

## **11.2 Steer Stopping (timed)**

- A. Roper will start from behind a required barrier.
- B. Barrier will be a minimum of 5 feet and a maximum of 15 feet
- C. Steer and roper both must have crossed barrier line before roping can commence, (i.e. No roping out of the box.)
- D. Only three catches are legal: horns, bell collar (around-neck), and half head, all other catches will be disqualified
- E. After the steer is roped, he must be brought to a stop **and** faced (turned facing the mule) before the flag is dropped.
- F. Ropers will be allowed only two loops; dally or hard and fast, at the option of the roper.
- G. Mule can compete only once in steer stopping class.
- H. A chute judge is required and the flagger must be mounted for the entire class.

I. There will be a maximum 1 minute time limit (suggested 45 seconds).

J. Penalties: Breaking the barrier - 10 seconds

### **11.3 Team Roping** (timed)

A. Header will start from behind a required barrier.

B. Barrier will be a minimum of 5 feet and a maximum of 15 feet.

C. Steer and roper both must have crossed barrier line before roping can commence. (i.e. No roping out of the box.)

D. Only three catches are legal: horns, bell collar (around neck), and half head, all others catches will be disqualified.

E. After the steer is roped, he must be brought to a stop and faced (turned facing the heading mule) before the flag is dropped.

F. Team will be allowed a total of three loops.

G. Header may dally or tie off hard and fast.

H. Mule may compete twice, but not with the same mule partner unless show management allows with requirement that riders swap ends.

I. A chute judge is required and the flagger must be mounted for the entire class.

J. There will be a maximum 1 minute time limit (suggested: 45 seconds).

K. Penalties:

1. Breaking the barrier - 10 seconds

2. Heeler catching one hind foot - 5 seconds

### **11.4 Buffalo Hunt** (timed)

A. Exhibitor is furnished with a mop with shortened strings which has been dipped in carpenter's chalk.

B. A steer, with a circle 18 inches in diameter marked equal distance

from the spine on each side, will be released from the chute just as in a roping event.

C. Exhibitor will start from behind a barrier. The object is to dab chalk within one of the circles then hold the mop up to indicate to the timer to stop the time.

1. Time will not stop until end of mop is above contestant's head.
2. Dabbed chalk mark must be fully within circle to count, re-dabs until successful will be allowed

D. There will be a maximum 1 minute time limit (suggested. 45 seconds).

E. Penalties: Breaking the barrier -10 seconds

### **11.5 Working Cow Mule (judged)**

A. The cow work portion of this event can be used individually. If both the cow work and the reined work are required at a show, then the scoring emphasis on the cow work portion shall be based on the mule maintaining control of the cow at all times, exhibiting superior cow sense and natural cow working ability without excessive reining or spurring. Failure of an exhibitor to attempt to complete the cow work portion of the class, as well as the reined work, will result in the exhibitor not being considered an entry in the class. A mule which attempts to complete the cow work but does not finish for any reason other than the two-minute time limit or rules 11.5 H 8c or H 9 will be scored accordingly at the judges discretion, A mule going off pattern in the reined work will receive a score of zero. A mule which attempts both the reined work and the cow work portion may be placed, even if disqualified in one portion of the class.

B. The approved pattern will be used and each contestant will cause his mule to travel at the gait indicated for each part of the pattern. When judging reined work, the judge should refer to the reining portion of the Rule Book for guidelines.

C. In approved working cow mule classes, any of the three approved patterns may be used. One pattern is to be selected by the judge and used by all contestants in the class.

D. For an ideal cow work, each contestant, upon receiving cow in the arena, shall hold the cow on the prescribed end of the arena for sufficient time to demonstrate the ability of the mule to contain the cow on that end. After a reasonable amount of time, the contestant shall take the cow down the

fence, making at least one turn each way on the fence. The contestant shall then take the mule to an open part of the arena and circle it at least once in each direction.

E. The judge should take into consideration the size of the arena, condition of ground and the disposition and degree of difficulty exhibited by the cattle worked.

F. At the discretion of either show management or the judge, cow work may be done immediately following each individual pattern work or immediately after completion of pattern work by all mules being exhibited. Scheduling must be posted prior to the class.

G. The cow work portion of the working cow mule class must be completed within two minutes.

H. The contestant's mule shall be penalized for general bad manners such as:

1. Biting; Striking; Running over the cow; 3 points
2. Mules that run past cow, for every mule's length past cow, 1 point
3. Hanging up on fence 3 points
4. Exhausting cow before circling 3 points
5. Failure to hold cow on end of arena 3 points
6. Failure to show sufficient control of cow while circling, 2 points
7. Deliberate spurring or use of romal forward of cinch, 5 points
8. Causes for zero score:
  - a. Mule that turns its tail to the cow
  - b. Any unnecessary roughness to the cow
  - c. Any mule out of control while working, thus endangering the rider crossing the path of the cow shall be called off cow
  - d. During the cow work, use of two hands on reins, except mules ridden two-handed in snaffle or bosal
9. Any mule that runs over a cow, causing a fall of mule and rider, shall terminate work and receive a score of 0.

I. If time and number of cattle permit, the judge may, at his discretion, award new cattle, to enable the contestant to show his mule's ability on the cow, based on the following criteria:

1. The cow won't or can't run
2. The cow won't leave the end of the arena
3. The cow is blind or won't yield to the mule
4. The cow leaves the arena

J. Scoring will be on the basis of 0 to 100, with 70 denoting an average performance. The same basis of scoring shall apply to both the reined work and cow work. In the event a tie, the entry with the highest cow work will be declared the winner.

K. Fall of mule and/or rider while being shown either in cow work or reined work shall not eliminate the entry.

L. The following characteristics are considered as faults:

1. Exaggerated opening of mouth
2. Hard or heavy mouth
3. Nervous throwing of head
4. Lugging on bridle
5. Halting or hesitation while being shown, particular when being run out, indicating anticipation of being set up
6. Losing a cow or unable to finish a pattern because a bad cow (Contestant should be penalized at judge discretion.)
7. Touching mule or saddle with free hand, except during the cow work portion of the class where the rider may hold onto the horn

M. The characteristics of a good working cow mule are:

1. Good manners
2. Shifty, smooth and having its feet under it at all time when stopping, hind feet should be well under
3. Should have a soft mouth and should respond to light rein, especially when turning
4. Head should be maintained in its natural position
5. Work at reasonable speed and still be under control of rider

N. When cattle are to be "worked", they shall be different cattle than the roping steers.

## WORKING COW MULE PATTERN I

(AQHA - 1996)

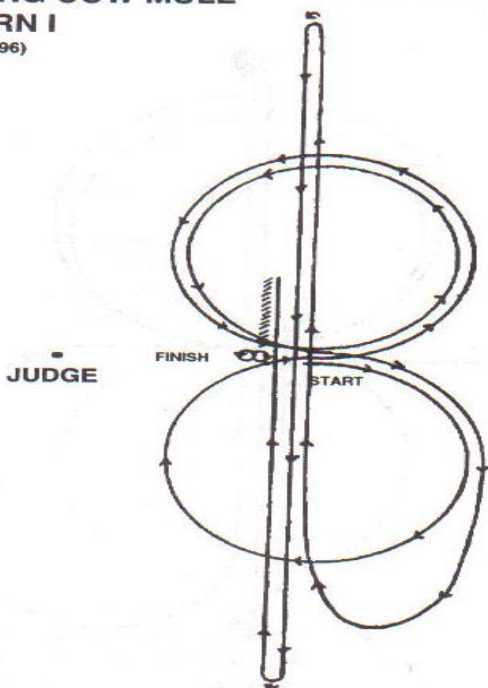

### • Mandatory Marker Along Fence or Wall

#### Ride Pattern as Follows:

1. Beginning at the center, facing right wall or fence, take a right lead and do a circle to the right, away from the judge, of moderate size and speed.
2. At the center of the arena, change leads and do two circles to the left both of moderate size and speed.
3. At the center of the arena, change leads.
4. Go to the end of the arena without stopping or breaking gait, and begin run down near the approximate center of the arena; run the length of the arena past marker.
5. Do a square, sliding stop, hesitate.
6. Turn left and begin a run to the opposite end of the arena; run length of arena past the marker.
7. Do a square, sliding stop, then hesitate.
8. Turn right, and begin a run down past the center marker of the arena.
9. Do a sliding stop, and back to the center of the arena or at least 10 feet. Let mule settle in approximate area of stop.
10. Do a 360-degree spin to the right.
11. Do a 360-degree spin to the left.
12. Hesitate to show completion of pattern.
13. Approach judge for inspection and dismissal.

## WORKING COW MULE PATTERN 2

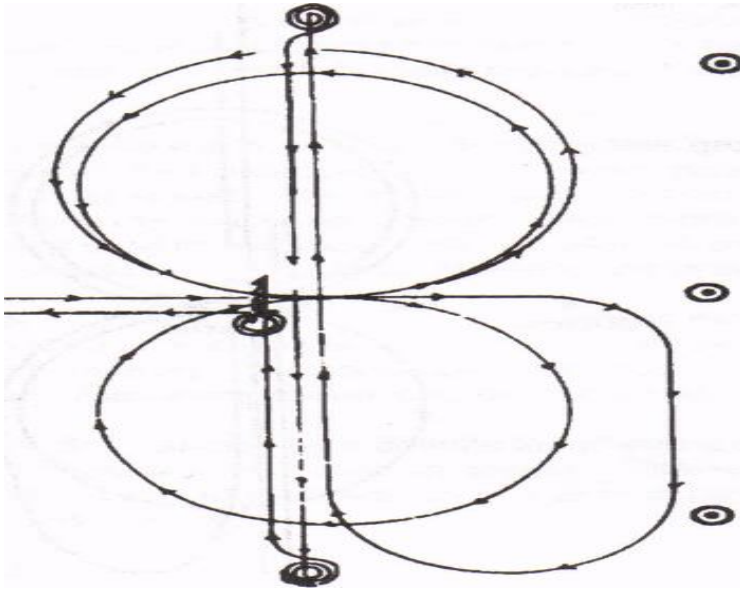

© Mandatory Marker along Fence or Wall

### Ride Pattern as Follows:

1. Begin at the center of the arena, facing right wall or fence. Take a right lead and complete a circle to the right, away from the judge.
2. At the center of arena, change leads and do two circles to the left, of approximately the same size.
3. At the center of arena, change leads.
4. Go to the end of the arena and without stopping or, breaking gait, start the run near the approximate center marker of the arena. Run full length of arena.
5. Do a square sliding stop, hesitate.
6. Do 2 1/2 spins right.
7. Run full length of arena past marker and do a square sliding stop, hesitate.
8. Do 2 1/2 spins left.
9. Run past center marker of arena; do a square sliding stop.
10. Back to center of arena (minimum 10-15 feet).
11. Do a 360-degree spin right or left.
12. Do a 360-degree spin opposite direction taken in #11
13. Hesitate to show completion of pattern.
14. Approach judge for inspection and dismissal.



## 12.1 Management Requirements

### A. Personnel needed (minimum)

1. Judge
2. Offside Line Judge
3. Cone/Pin Man
4. Secretary

### B. Equipment

1. Sled (suggested dimensions: 4 feet 2 inches X 4 feet 2 inches, with 9000 **lbs.** weight capacity)
2. Hooking Harness attached to both ends of sled
3. Cone (or pin) with rope attached
4. 2 Lengths of yellow poly rope (working length of arena)
5. 3 Whistles
6. 2 Stopwatches
7. Calculator
8. Weights (weight truck with lift is nice, but concrete or salt blocks, railroad iron or anything else which will fit safe on the sled will work.)

## 12.2 Pull Rules

### A. Class Rules

1. Mules only will be allowed. A team will consist of two mules.
2. All teams will be weighed in on scales as specified by Show Management and during a defined period of time specified by Show Management. Order of pull is determined by combined weight of team in a light to heavy graduation.
3. Any changing of individual team animals after weigh in will be cause for disqualification.
4. ANY MISCONDUCT BY DRIVERS OR HANDLER WILL NOT BE TOLERATED AND WILL RESULT IN DISQUALIFICATION.
5. Teams will be divided into weight divisions. Large pulls should have 4 weight divisions: 0 -900 pounds, 901-1400 pounds, 1401 -1900 pounds and 1901 pounds and over. Smaller pulls are best divided into 3 weight divisions calculated as to the fairest division of teams present; if

divided in 2 weight divisions Management can either use the 1300 pound over and under method or calculate the median of the teams present. There must be at least six teams in each weight division or the division could be combined with the next lighter division at the discretion of management.

6. Teams will pull a percentage of their combined weights progressively starting at a minimum of 75% or above. Two hundred pounds will be added per round as needed to determine the winner in the light weight division, 300 pounds in the medium weight division, 400 pounds in the heavy weight division and 500 pounds in the super heavy weight division. Smaller pulls with 3 weight divisions should add 200 pounds per round to the light weights, 300 pounds to the medium weights and 400 hundred pounds to the heavy weights. In the case of a pull with two division, add 200 hundred pounds to the light weights and 300 pounds to the heavy weights. Driver has the option to pass at his turn at any weight on the first attempt.
7. Each exhibitor must furnish own harness, traces, **etc.** Teams must use some type of quick connector from double tree to sled. **Two minutes** will be allowed for hookup. Team must hook-up or pass within the two minute limit or it will be considered an attempt. **SIXTY SECONDS** will be allowed after hook-up to complete pull. Pin must lay flat on ground for successful pull.
8. Distance of pull will be 10 feet. Pull must be continued in the same direction as last pull unless mule's nose touches end line. A ten foot alley will be used for the two lighter weight divisions, and a twelve foot alley for the two heavier weight divisions. An additional 10 foot lane off of the pulling alley will be used only by officials, headers or helpers. Controlled swinging of the sled will be allowed. If sled is pulled at an angle, the sled must be straightened (to the Judges satisfaction) by the same team before the next attempt, be it theirs or the next team.
9. Team will be allowed two attempts to complete pull at each weight. Crossing outside alley lines will result in one attempt. If called, driver has option to unhook after first attempt and come back at end of that weight for final attempt.
10. Winner will be determined on last successful pull plus measurement. Any attempt may be measured but that attempt will be considered final. The final measured attempt must immediately

follow a successful pull. If a foul occurs on the final attempt, the last successful pull will be used. (Equipment failure see rule 15)

11. Teams will be allowed only one driver and one assistant. If assistant is used, he must stand outside pull alley behind double-tree during pull. Driver cannot cross double-tree during pull and must drive from behind the double-tree. Crossing double-tree during pull will be a disqualification. Driver or assistant must not obstruct Line Judge's view. Obstruction, after one warning, will be considered an attempt.

a. No Youth Exhibitors will be allowed.

12. Mules must not "jump into the collars". (Judges will have to rule on teams that are hard to handle.) The first warning will be considered an attempt. The second warning will result in disqualification. A disqualified team will be ruled out at the last successful pull.

13. Double tree must be off ground before pull commences. After pull commences, pull will be considered over when double tree touches the ground.

14. No whips or other pieces of equipment other the driving lines will be allowed to coax teams into pulling. It is permissible to whistle, yell or jump up and down. Touching team after pull commences will automatically be a disqualification and team will be ruled out at last successful pull.

15. Equipment failures will be considered an attempt after team has hooked. If team has an equipment failure, contestant may try to repair equipment and pull again as long as weight remains the same. If weight has been added to the sled before repairs can be made, team may not pull again. All equipment failures will be measured in the event team cannot come back. Last weight successfully pulled will be used as final standings.

16. No abusive bits will be allowed. Teams will be checked upon entrance to the arena. See Bit Rules - III 3 for illegal bit descriptions. Judges will rule on presence blood and/or abuse which may result in disqualification.

17. All teams will be subject to blood and/or urine testing. Presence of stimulants or depressants will be grounds for complete

disqualification.

18. Entry fees, added money (if any), amount of jackpot and the distribution of the prize money must be stated on the flyer. Larger pulls with large amounts of added money **can pay** through 6th place: 25%, 19%, 17%, 15%, 13% and 11 %. Smaller pulls usually place through sixth but pay through 4th: 40%, 30%, 20% and 10%.

B. Rule Administration: These pull rules have been created to: FIRST--protect the animals and SECOND-insure a fair pulling event for all exhibitors. It is the responsibility of Show Management and the personnel who function officially **as** judges to administer the rules in such a manner that these two things happen. Failure to adhere to the above rules will result in removal of sanctioning for the pull as well as to any show connected with the pulling event, and any further action necessary will be decided by a Hearing Committee according to the Texas Donkey and Mule Organizations Rule Book.

# Rules for Miniature Donkeys 36” and under, Miniature Mules 38” and under

## 1. Show Regulations Concerning Miniature Donkeys and Miniature Mules (Both will be referred to as "Miniature")

- A. Registration: A registration certificate is not required on every **miniature** at every sanctioned show in Texas. It is strongly recommended that owners, handlers, and/or agents have a copy of the registration papers readily available which may be needed as proof of ownership, age of animal, or parentage, etc.
1. Proof of ownership shall be the name on the registration certificate.
  2. For a lease of a **miniature** to be recognized for showing purposes, a copy of said lease signed by both lessor and lessee must be provided to the sanctioning club. Only the lessee will be listed on all show programs and awards until such lease is terminated. The lease shall provide the effective date of lease, the name and registration of the **miniature**, and a termination date. The lessee will be considered the owner of the **miniature** for the period of the lease for show purposes only
- B. Proof of Negative Coggins is required for each animal brought onto the show grounds. No Exceptions. The documentation must be the original Coggins, dated within one year of show date. No copies will be accepted. Health certificates may be required if specified in the show premium/entry form. When health certificates are not required, show management shall make reasonable efforts to see that all **miniatures** brought to the show grounds are in good health and free from noticeable disease.
- C. Jacks two years and over must be shown in a bridle or with a stud chain worn over the nose or under the chin.
- D. Exhibitors age 18 years and under may not show a jack in the show ring or be in control of a jack while on the show grounds. **See exception for youth exhibitors showing in**

### **the adult divisions (3.B.4.)**

- E. For the purpose of the show rules, performance classes will include any point earning class other than halter and showmanship. Halter and showmanship may be included for high point championships if included in the show bill.
- F. Pre-Green - to be entered in a Pre-Green Performance class a **miniature** must be under three (3) years of age. If a Pre-Green class is not offered, the **miniature** may then show in a Green class without affecting their Pre-Green status.
- G. Green - This division is designed specifically for mature animals learning skills necessary for performance classes.
  - 1. Animal must be at least 3 years old.
  - 2. Animal may not be shown in Green for more than 2 calendar years.
  - 3. First calendar year begins upon entry into its first performance class as a three year old. The second calendar year is the calendar year immediately following the first calendar year.
  - 4. Participation in halter and showmanship classes will NOT count towards the two (2) year eligibility for Green classes.
  - 5. Animal may not show in both Open and Green Division in the same show.
  - 6. If a show offers only Open classes, a **miniature** (qualified for Green classes) may compete in this show without affecting its Green status.
  - 7. Once an owner/handler voluntarily moves a **miniature** from Green into Open at any show where both divisions are offered, they forfeit their remaining Green eligibility for that animal.
  - 8. Exceptions to the time limit rule involving extreme circumstances would be heard by the Texas Rule Book Committee - Hearing Committee.
  - 9. An animal that has been shown two years as Green then changes ownership, may not be shown again in Green.
  - 10. Problems or protests regarding animals entered as Green MUST BE MADE WITHIN 48 HOURS AFTER COMPLETION OF THE SHOW. Actual protests must be accompanied by the normal \$50.00 check, which will not be returned if the protest is overruled. Each Club is encouraged to retain accurate and accessible records regarding Green animals, but it is expected that exhibitors will use the honor system.
    - a. **Protests must be made within 48 hours after completion of the show.**
    - b. Proof obtained by a protestor after the show can be provided

at the beginning of the next show to prevent further entry in Green classes, if necessary.

c. Special consideration may be given in a case where a new member, who is unfamiliar with the rules, has entered and competed with an animal in both Green and Adult classes but actually prefers to continue in Green. Each Club must arbitrate problems such as this on an individual basis, but it is noted that a one-time exception would be reasonable.

H. Open – Animals Age 3 & over not being shown in green.

I. All **miniatures** entered in jumping, driving classes, or any harness class (i.e. snigging) shall be three (3) years old or older. Exception: Pre-green hunter class.

J. Foals shown in the foal classes MUST be a minimum of six (6) months of age (actual age). Proof of age may be required.

K. No **miniatures** shall be allowed to participate when unsoundness or injury is sufficient to be considered an act of cruelty.

L. No person shall administer nor cause to be administered to a **miniature**, either before or during an event, any medication, drug, or mechanical device, or artificial appliance, surgical or non-surgical procedure, which is of such character as to affect the **miniature's** performance or appearance at that event. Upon discovery, show management shall immediately disqualify the **miniature**.

M. No person shall alter, change, or attempt to hide or enhance the natural color of the body including legs of a **miniature** by dye, bleach, or paint. Hooves may be colored. Any **miniature** that has been color enhanced must be disqualified for the entire show, and all previous trophies, ribbons, and points will be disallowed for that show.

N. Age of **Miniature** - the age of a **miniature** for the purpose of competition shall be computed on the basis of calendar year starting January 1 of the year foaled. It is a weanling during the calendar year in which foaled and a yearling during the first calendar year following its foaling date, regardless of the time of the year foaled.

O. An electronic timer shall be set-up and used for all timed events with a backup stop-watch timer. If an electronic timer is not available a minimum of two stop watches and two timers shall be used. One timer will be designated the official timer and other the back-up timer.

P. No jumps over six inches (6") will be included in any **miniature** class where pre-green **miniatures** (under 3 years old) are competing. Jumps over twelve inches (12") are NEVER

allowed in any In-Hand Trail class.

- Q. Although it is NOT recommended to show miniature donkeys and miniature mules in the same class, they may be combined for classes if designated as such on the show flyer.

## **2. Ring Procedures**

- A. Show Attire: It is the tradition of the show ring that all handlers and drivers be correctly attired for the class. Hats, boots, and long sleeved shirts/blouses or jackets are REQUIRED in all classes except where exempted for specific classes. (Exception: Slinkies, short sleeved or sleeveless shirts/blouses will be allowed when worn under a jacket) Gloves are OPTIONAL in all classes. Failure to be properly attired will result in a penalty by the judge. See individual class rules for specific show attire and exceptions. No shorts, open-toed shoes, t-shirts, or ball caps are allowed in any classes, except the Costume Class. Management and/or officials must bar any person from entering the ring when not suitably attired to appear before an audience. Hard hats are required for persons age 18 and under in any driving class. Adults may wear protective head gear as optional equipment. Advertising of Farm or Ranch on clothing, miniature, or cart will not be allowed.
- B. All miniature are to be handled and shown through an entire class by the same person.
- C. It is the exhibitor's responsibility to be on time for classes. All classes will only be called three (3) times. Once a class is called and the gate is opened to enter the ring, the gate will be closed after two minutes has elapsed from the time the first miniature/exhibitor enters the ring. If sufficient entries warrant, the gate may remain open until the last miniature/exhibitor enters the ring, as long as there is a continuous flow of entries into the ring. Announcer/gate person shall state when timing of the two minutes begins. Once class is called and the gate is closed, any miniature leaving the arena for any reason is disqualified. SHOULD THERE BE A NEED FOR TACK CHANGE, THE ANNOUNCER WILL STATE FOR THE EXHIBITORS TO WORK AT WILL. Announcements to barn areas are a management courtesy - not mandatory.
- D. Names of miniature or exhibitors will not be made known to the judge prior to the show or during the class, as in announcements.
- E. Exhibitors will be issued a number for each miniature to be displayed whenever the miniature is in the arena.

- F. Unsportsmanlike conduct, including but not limited to conduct designed to distract a **miniature** or otherwise interfere with the showing of an exhibitor's **miniature**, will not be tolerated. Offenders will be asked to leave the show arena.
- G. For the purpose of safety, an unruly **miniature** may be excused from the ring by the Judge.

### **3. Exhibitor Show Age**

A. The age of an individual on January 1<sup>st</sup> will be considered to be the age of the exhibitor throughout the entire year.

B. Youth shall be 18 years and younger.

1. High Point is tallied on one youth/one animal combination.

2. A Youth may not show a jack in the show ring or be in control of a jack on the show grounds.

3. Youth exhibitors may show animals in any halter class including a mixed gender class where adults are showing jacks.

4. Youth that are age 17 by January 1st of the current year will be allowed the option of advancing to the Adult divisions, if showing a **miniature**. Once the youth has voluntarily advanced, all points and eligibility in the Youth division are forfeited. This exhibitor may show a jack in the Adult division.

C. Sub-Youth shall be 10 years and younger.

1. A Sub-Youth who has shown in Sub-Youth in a current year may elect to advance to Youth classes (or if having advanced, return to Sub-Youth classes) but will forfeit all accrued points with the change.

2. If Sub-Youth division is not offered at a show the exhibitor may show in Youth classes without losing their eligibility.

3. A sub-youth who moves up in the middle of a show year will forfeit any points accrued in the lower category.

4. High point is tallied on one sub-youth/one animal combination.

5. A sub-youth must be capable of handling the animal alone at all times. Each sub-youth must have an ADULT **assistant** who will remain in a designated area in the show ring unless an uncontrollable instance arises. Dress code also applies to the **assistant**.

6. A Sub-Youth may not show a jack in the show ring or be in control of a jack on the show grounds.

D. Pee-Wee exhibitors shall be 5 years and younger, age to be determined as of January 1.

1. A Pee-Wee may elect to show in the Sub-Youth classes but not in both. Once a Pee-Wee voluntarily moves up to the Sub-Youth division they can not return to the Pee-Wee division.

2. If Pee-Wee is not offered the exhibitor may show in Sub-Youth classes without losing their eligibility.

3. Pee-Wee classes are judged but not placed. All exhibitors are given an equal award.

#### **4. Awards - Halter Champion**

A. Model/Reserve Model Halter (also known as Champion/Reserve Champion) - The object of this class is to select the animal in the division and/or show that comes nearest to the ideal animal.

B. Class Procedure:

1. The first place and second place animals in all point earning halter classes will be lined up with the second place animal directly behind the first place animal; then the front row will be judged for Model.

2. The second place animal directly behind the animal picked for Model will then take its place in the front row to be judged for Reserve Model or Reserve Champion of that division.

C. Best of Breed Champion is then selected from the Champion Jack, Champion Jennet and Champion Gelding. One **miniature** is chosen as overall Best of Breed. This championship is preferred in shows with large entries and multiple halter age divisions.

#### **5. Performance Champion or High Point Show Champion (All Divisions)**

A. This award shall be based on total points accumulated by a single animal in designated classes. Halter and showmanship classes may be included or excluded as high point classes. The show bill must designate all classes to be included in high point.

B. To qualify for this award in the Open and Green divisions, the

**miniature** must be entered and shown in at least one performance class where the **miniature** is shown in harness. In the Pre-Green Division the **miniature** must be entered and shown in at least one performance class.

- C. A show shall use the system for points as outlined in the General Rules, Rule 1.6 Points.

## **6. Halter Divisions (Optional for inclusion in High Point)**

**\*\*Foals must be a minimum of 6 months old, actual age\*\***

Foaled in calendar year of show

Foals Jacks

Foals Jennets

Foals Gelding

Yearlings are foaled in the calendar year preceding show year

Yearling Jacks

Yearling Jennets

Yearling Geldings

Age groups may be combined. Jacks, Jennets, and Geldings may not be combined beyond the yearling divisions.

2 year old Jacks

2 year old Jennets

2 year old Geldings

3 & 4 year old Jacks

3 & 4 year old Jennets

3 & 4 year old Geldings

5 years old and over Jacks

5 years old and over Jennets

5 years old and over Geldings

Model and Reserve Model **Miniature Donkey**

## **7. Specialty Halter Classes**

Champion and Reserve Champion Halter Jack - First and second place winners of the Jack classes 2 years and older.

Champion and Reserve Champion Halter Jennet - First and second place winners of the Jennet classes 2 years and older.

Champion and Reserve Champion Halter Gelding - First and second place winners of gelding classes 2 years and older.

Best of Breed will be Champion Halter Jack, Champion Halter

Jennet and Champion Halter Gelding two years old and over.  
Junior Champion and Reserve Junior Champion - First and second place winners of the foals and yearling classes.

Get of Sire - 3 offspring of sire

Produce of Dam - 2 offspring of Dam

\*All **miniatures** competing in the Production class MUST compete in their respective halter class in the same show.

Color Class

Best Matched Pairs

**8. Performance Classes** (All **miniatures** 3 years & over)

Pleasure Driving Working Single - Open Adult  
Pleasure Driving Working Single - Green Adult  
Pleasure Driving Working Single - Youth  
Pleasure Driving Working Single - Sub-Youth  
Pleasure Driving Reinsmanship - Open Adult  
Pleasure Driving Reinsmanship - Green Adult  
Obstacle Driving - Open Adult  
Obstacle Driving - Green Adult  
Obstacle Driving - Youth  
Obstacle Driving - Sub-Youth  
Gambler's Choice (timed event) - Open Adult  
Gambler's Choice (timed event) - Green Adult  
Gambler's Choice (timed event) - Youth  
Gambler's Choice (timed event) - Sub-Youth

**9. Game Driving Classes** (all events are timed)(All **miniatures** 3 years & over)

Cloverleaf Barrel Driving - Open Adult  
Cloverleaf Barrel Driving - Green Adult  
Cloverleaf Barrel Driving - Youth  
Cloverleaf Barrel Driving - Sub-Youth  
Single Stake Driving - Open Adult  
Single Stake Driving - Green Adult  
Single Stake Driving - Youth  
Single Stake Driving - Sub-Youth  
Keyhole Driving - Open Adult  
Keyhole Driving - Green Adult  
Keyhole Driving - Youth  
Keyhole Driving - Sub-Youth  
Pole Bending Driving - Open Adult

Pole Bending Driving - Green Adult  
Pole Pending Driving - Youth  
Pole Pending Driving - Sub-Youth

### **10. Game Halter Classes**

In-Hand Jumping - Open Adult (miniatures 3 yrs & over)  
In-Hand Jumping - Green Adult (miniatures 3 yrs & over)  
In-Hand Jumping - Youth (miniatures 3 yrs & over)  
In-Hand Jumping - Sub-Youth (miniatures 3 yrs & over)  
Lead Race - Open Adult  
Lead Race - Green Adult  
Lead Race - Pre-Green Adult  
Lead Race - Youth  
Lead Race - Sub-Youth  
Lead Obstacle Race - Open Adult  
Lead Obstacle Race - Green Adult  
Lead Obstacle Race - Pre-Green Adult  
Lead Obstacle Race - Youth  
Lead Obstacle Race - Sub-Youth  
Coon Jumping - Open Adult (miniatures 3 yrs & over)  
Coon Jumping - Green Adult (miniatures 3 yrs & over)  
Coon Jumping - Youth (miniatures 3 yrs & over)

### **11. In-Hand Trail Classes**

In-Hand Trail - Open Adult  
In-Hand Trail - Green Adult  
In-Hand Trail - Pre-Green Adult  
In-Hand Trail - Youth  
In-Hand Trail - Sub-Youth

### **12. Optional Classes**

Snigging (Timed Event) - Open Adult (All miniatures 3 years & over)  
Snigging (Timed Event) - Green Adult (All miniatures 3 years & over)  
Snigging (Timed Event) - Youth (All miniatures 3 years & over)  
Log Drag - Open Adult (All miniatures 3 years & over)  
Log Drag - Green Adult (All miniatures 3 years & over)  
Log Drag - Youth (All miniatures 3 years & over)  
Open Adult Showmanship (optional for high point)  
Green Adult Showmanship (optional for high point)  
Pre-Green Adult Showmanship (optional for high point)  
Youth Showmanship (optional for high point)  
Sub-Youth Showmanship (optional for high point)  
Pre-Green, Green and Open Adult Hunter

Versatility Class - Open Adult (All **miniatures** 3 years & over)  
Versatility Class - Green Adult (All **miniatures** 3 years & over)  
Versatility Class - Youth (All **miniatures** 3 years & over)  
Costume Class

**13. Optional Awards** for show High-Point **Miniatures**:

Champion High-Point **Miniature** - Open Adult  
Reserve High-Point **Miniature** - Open Adult  
Champion High-Point **Miniature** - Green Adult  
Reserve High-Point **Miniature** - Green Adult  
Champion High-Point **Miniature** - Pre-Green Adult  
Reserve High-Point **Miniature** - Pre-Green Adult  
Champion High-Point **Miniature** - Youth  
Reserve High-Point **Miniature** - Youth  
Champion High-Point **Miniature** - Sub-Youth  
Reserve High-Point **Miniature** - Sub-Youth

## **Halter Class Rules**

**14. Halter - Conformation**

- A. **Miniatures** are shown in hand at the walk and trot. Animal shall be judged individually, standing squarely and naturally.
- B. **Miniatures** are judged on the priority of conformation which includes fitting and condition, quality, presence and way of going. Disposition and manners shall also be considered.
- C. Class disqualification: Cryptorchidism in mature jacks age 3 years and older (a jack with one or both testes undescended), height in excess of 36" and/or excessive overbites/under bites that exceed ¼" will be disqualified. Handler/exhibitors may show teeth when requested by the judge; judge should not touch **miniature**'s mouth. Unruly or ill-mannered **miniatures** to be excused from the arena at the judge's discretion.
- D. General appearance: The ideal **miniature** should be attractive, well balanced, sound, strong and sturdy. The animal should be pleasing to the eye as the various parts blend together in a nicely coupled picture. The **miniature** should have an alert expression and presence. Ideally, Jennets should look more feminine and slightly more refined while jacks should be more stocky and masculine.
- E. **Miniatures** must be serviceably sound, in good condition, and well groomed. Body clipping of young foals is not required, nor is it required for **miniatures** of any age when the show is held during inclement weather, winter, early spring, etc.
- F. No whips, crops or other device(s) are allowed in halter classes. **Miniatures** shall be shown in a leather, rope or nylon

halter that is correctly fitted and adjusted for said **miniature**. A lead rope is required. The use of a chain shank is optional except for jacks 2 years old or over who must be shown with a chain shank, rope under the chain, or stud bridle. Equipment must be humane and in good condition. Silver not to count.

- G. No artificial aids for control (such as canes, show sticks, or whips) or for attention (such as cigarette lighters, paper wrappers, food, hats, or noise makers) may be used during halter classes.
- H. A **miniature** may only be shown in one point earning halter class.
- I. If offered, Foal and Yearling classes may count as high point classes in the Pre-Green Division.

### **15. Halter - Get of Sire**

- A. Three (3) Get, either sex, must be shown.
- B. Sire need not be present. The Get need not be owned by owner of sire.
- C. All 3 entries shall be entered under the name of the sire.
- D. A separate entry number shall be issued to each group of **miniatures**. The entry number is to be placed on the lead exhibitor in the group.
- E. Emphasis is placed on reproduction likeness, uniformity, quality of breed characteristics, and similarity of conformation.
- F. More than one set of entries for sire may be entered in the same class.
- G. \*All entries must compete in their respective halter classes in the same show. See also rule 14 D & E.
- H. This is not a point earning halter class.

### **16. Halter - Produce of Dam**

- A. Two (2) produce, either sex, must be shown.
- B. Dam need not be present. The produce need not be owned by owner of dam.
- C. Both entries shall be entered under the name of the dam.
- D. A separate entry number shall be issued to each group of **miniatures**. The entry number is to be placed on the lead exhibitor in the group.
- E. Emphasis is placed on reproduction likeness, uniformity, quality of breed characteristics, and similarity of conformation.
- F. More than one set of entries for dam may be entered in the same class.

- G. \*All entries must compete in their respective halter classes in the same show. See also rule 14 D & E.
- H. This is not a point earning halter class.

### **17. Halter - Color Class**

In color classes **miniatures** will be judged on the following basis: natural color of the **miniature** = 80% and conformation = 20%. In color classes **miniatures** are to be circled both ways of the ring in order to judge the 80% color. **Miniatures** must be lined up head to tail in the center of the arena to judge the 20% conformation. If offered, the class may be divided by sex. At show managements discretion this class may be divided into spots and solids. This is not a point earning halter class.

### **18. Halter - Best Matched Pairs**

- A. This class is open to all **miniatures** six months old and over.
- B. The pair is to be judged 50% on conformation and 50% on likeness (to include size, color, type, etc.)
- C. A single handler may handle both **miniatures** or two handlers may show in the pairs competition.
- D. A separate entry number shall be issued to each group of **miniatures**. The entry number is to be placed on the lead exhibitor in the group.
- E. This is not a point earning class.
- F. **Miniatures** do not have to be related.

**Rules 19 thru 24 are unassigned.**

### **25. In-Hand Jumping**

- A. **Miniatures** must be three (3) years or older to compete in this class.
- B. All courses for the In-Hand Jumping Class including Jump-off courses, must be posted at least one (1) hour prior to the scheduled time for the class. Show management should make every effort to post the patterns as early as possible. Course diagrams must show with arrows the directions each obstacle must be taken. A start and finish line must be established at least twelve (12) feet from the first and last obstacle and indicated by two markers at least four (4) feet apart. **Miniatures** (exhibitors optional) must cross the line in the proper direction to start and complete the course.
- C. **Attire: Standard show attire is required except exhibitors may wear any type of footwear except open-toed shoes.** Jumps may be made of PVC piping or wood. PVC is preferred over wood for the safety of the **miniature**. All jumps must be

at least five (5) feet wide between the standards, with standards a maximum height of thirty six inches (36"). A minimum of twenty (20) feet between jumps is required, with the exception of an in and out. All post and rail jumps must have a ground pole.

- D. Jumpers are to be judged on accumulated faults only on the first go. Minimum height for jumps must be 14" and maximum height 24" for first jumping round. Exhibitors may go over the jumps with **miniature**. Whips or crops are not permitted.
- E. Jumps may include brush, triple bar, water, and/or similar types of jumps. Brush jumps must have a visible bar on top. There will be a minimum of four jumps, with a maximum of eight jumps.
- F. Scoring: Jumpers are to be scored on a mathematical basis and penalty faults include knockdowns, refusals, and elimination as follows:
  - 1) Knockdowns - Each knockdown is 4 faults. An obstacle is considered knocked down when, during a jump, a **miniature** or handler, by contact, lowers the established height of the jump in any way.
  - 2) Refusals - Each refusal is 3 faults. Stopping at any obstacle without knocking it down and without backing followed quickly by jumping from a standstill is not penalized. However, if the halt continues or if the **miniature** backs even a single step, side steps or circles to retake the jump, a refusal is incurred.
  - 3) Circling more than once after crossing starting line is 3 faults. This fault consists of any form of circle or circles whereby the **miniature** crosses its original track between two consecutive obstacles or stops advancing toward or turns away from the next jump except to retake a jump after a refusal.
  - 4) Crossing your own path (as in circling between jumps, not as in retaking a jump from a refusal) is 4 faults.
  - 5) Elimination - 3 refusals, off-course, or fall of **miniature** or handler.
- H. Jump-Offs - In the case of a clean first round and for placement of class, the number of jumps will be decreased to four (4), and the heights of jumps to be increased not less than 4", and no more than 6". The jump off shall be a timed event. The first round is decided by adding faults incurred

over the course. **Miniatures** with clean rounds go into the jump-off. In the event of equality of faults after the first round, there will be a jump-off for first place only. Other placings which tie may either flip a coin or be awarded duplicate ribbons at show management's discretion. After the timed jump-off, the **miniature** with the (1) the least amount of faults in the jump-off round and (2) the fastest time shall win the class. If faults are equal, fastest time wins.

### Sample In-Hand Jumping Course

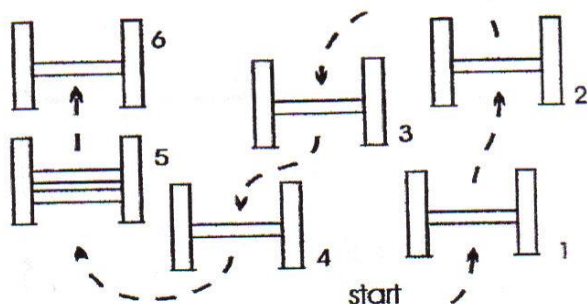

## 26. Coon Jumping

- All **miniatures** must be handled by one person only. No helper is allowed to handle the **miniature**. Exception: If a handler is exhibiting more than one animal in the class. An assistant may hold the animal in the line.
- The event starts with the bar at 16"-20" and is raised 2"-3" after every **miniature** in the class has jumped (or attempted to jump). The initial jump must be cleared to qualify for placing.
- Handler may stand to either side of box but must hold lead rope in hands at all times. Handler may go over the jump with the **miniature**.
- Jumps are to be of a breakaway type, either PVC piping or wood. (PVC is preferred for the safety of the **miniature**.) The jump top rail should be ten feet in length but not protrude outside the box in such a way as to interfere with the handler. The jump standards should not be higher than 4 feet tall.
- Miniatures** will jump from inside a 10' marked box. The 10'x10' box may be marked with chalk, paint or a line drawn

in dirt but may NOT be marked by rope or string.

- F. **Miniatures** must be at least three years old.
- G. Both front and rear feet must come to a complete stop inside the 10' x 10' box before jumping. The **miniature** may not simply trot into box and take the jump without stopping or they will be disqualified. **The miniature will have 90 seconds from when the first foot hits the ground, or three attempts-whichever comes first. An attempt is an approach to the bar.** Stepping out of the box will be an attempt. Knocking down the bar is an elimination.
- H. In the event of a tie there will be a jump-off. **Miniatures** must make a clean jump. **Miniature** may rub the jump with chest or belly so long as the bar is not knocked down. The **miniature** must land in an upright position.
- I. **Miniature** may be jumped in a bridle or halter. A rope or chain under chin on halter is allowed, however no choke ropes over the neck are allowed.
- J. No whipping or mistreatment of any kind shall be tolerated. In the event such treatment takes place, the entry will be disqualified.
- K. The handler may provide their own blanket to be placed on the jump. An assistant may place and remove blanket for handler.

The winner is determined by the animal that clears the highest jump. In the event of a tie, if neither **miniature** is successful at the new height **the judge will place them by the fastest time at the last successful jump.**

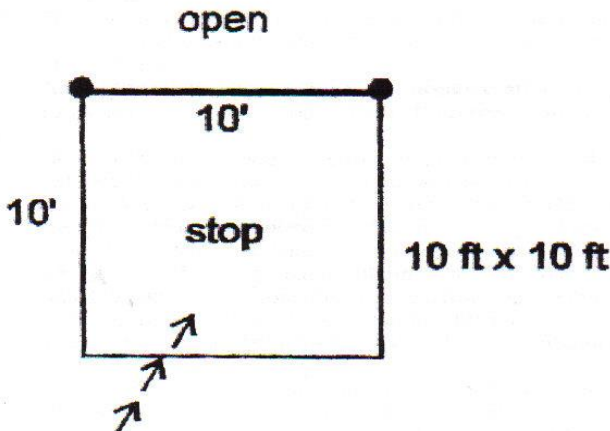

## **27. Lead Race**

- A. This is a timed event where the **miniature** is led across a starting line, down center of arena, around pole or cone and back across the starting/finish line. **Miniature** shall be led and may wear either a halter or bridle. A chain or rope under chin of halter or stallion bridle is required for mature jacks, optional for all others. No crops or whips are allowed.
- B. **Miniatures** shall be run individually. The fastest time will be the winner. **Miniatures** may walk, trot, or lope.
- C. The distance between the starting line and the pole or cone shall be 50-75 feet.
- D. **Attire: Standard show attire is required except exhibitors may wear any type of footwear except for open-toed shoes.**

## **28. Lead Obstacle Race**

- A. This is a timed event where the **miniature** is raced through a minimum of 3 and a maximum of 6 obstacles. The **miniature** shall be led and may wear either a halter or bridle. A chain or rope under chin of halter or stallion bridle is required for mature jacks, optional for all others. No crops or whips are allowed.
- B. **Miniatures** shall be run individually through the pattern. **Miniatures** may walk, trot, or lope.
- C. The courses for the class must be posted at least one hour prior to the scheduled time of the class. Course diagrams must show, with arrows, the direction each obstacle must be taken, and markers or a line must indicate the start and finish of the course.
- D. Show management should make every effort to set up the course in the shortest distance possible.
- E. No jumps over 12 inches will be allowed. In classes where there are animals under 3 years of age the jumps shall not be over 6 inches.
- F. If a **miniature** disturbs an obstacle a 5 second penalty is assessed for each occurrence. The participant's total time will be the run time plus any penalties. The fastest time will be the winner.
- G. **Attire: Standard show attire is required except exhibitors may wear any type of footwear except for open-toed shoes.**

## 29. Pre-Green, Green and Open Hunter

### A. General Rules

1. The courses for hunter classes must be posted at least one hour prior to the scheduled time of the class. Course diagrams must show, with arrows, the direction each obstacle must be taken, and markers or a line must indicate the start and finish of the course.
2. The age for a **miniature** will follow the guidelines found in **Rule 1.8 M, and Miniature Show Rules 1.F**. Pre Green **miniatures** must be a minimum of 6 mos old. Judge(s) and **Ring steward** may walk Hunter course with designer and exhibitors prior to start of class.
3. **Attire: Standard show attire is required except exhibitors may wear any type of footwear except open-toed shoes.**

### B. Hunters

1. Hunters are to be judged on style, manners, and way of going, with preference given to those **miniatures** who cover the course at an even pace, with free flowing strides, as in a brisk trot or canter, but must maintain same gait throughout the entire course. Circling once upon entering the ring and once upon leaving the ring is permissible. Charging fences, or not maintaining the same gait throughout the entire class should be penalized. Any unsound **miniature** will be eliminated. **Miniatures** shall not be required to re-jump the course.
2. The course design for hunters should follow the same requirements as the course for In-Hand Jumpers.
3. Jumps: There will be a minimum of four jumps and a maximum of six jumps. The jumps can range in height from three to six inches off the ground for Pre Green, and six to fourteen inches for Green and Open. Jumps should be of attractive design but constructed of a material so as not to cause danger to the **miniature**. Jumps may be made of PVC, natural post and rail, brush, stone wall, white board gate, hedge, etc. All jumps must be at least five feet in width, no wider than six feet, with a minimum of twenty feet between jumps. No wings or additions are allowed outside the jump standards.
4. Causes for elimination in Hunter classes:
  - a. Three (3) refusals
  - b. Off Course

- c. Crossing your own path. It is permissible to circle to re-take a jump from a refusal, but it is not permissible to circle before taking a jump for the first time.
  - d. Fall of miniature or exhibitor
  - e. Carrying a whip
  - f. An unsound miniature
6. Major faults to be scored:
- a. Knockdowns
  - b. Touches
  - c. Refusals
  - d. Bucking or Kicking
  - e. Spooking or shying
  - f. Wringing of tail
  - g. Showing an obstacle to a miniature
  - h. Not maintaining an even pace
7. Faults defined:
- a. Knockdowns – an obstacle is considered knocked down when in jumping an obstacle, a miniature or handler, by contact, lowers the established height of the fence in any way – 4 faults.
  - b. Refusals – If an animal stops at an obstacle, backs away from an obstacle, or side steps or circles to retake the fence, then a refusal is incurred:
    - 1<sup>st</sup> refusal ..... 4 faults
    - 2<sup>nd</sup> refusal..... 4 faults
    - 3<sup>rd</sup> refusal..... disqualification
  - c. Circling – any form of circle or circles whereby the miniature crosses its original track between two consecutive obstacles, stops advancing toward the next obstacle, or turns away from the next obstacle. (It is permissible to circle to re-take a jump from a refusal.) – 3 faults.

**30. Snigging (Timed)**

- A. Snigging is an Australian word for dragging a load behind an equine. As a class, snigging tests how quickly and accurately a miniature and his handler can move a load through a specific pattern.
- B. Snigging shall be done by driving the miniature pulling a log. The miniature must wear a harness. The traces of the harness are attached to a singletree which is attached to a log and the log is drug safely behind the miniature. The exhibitor shall

ground drive the harnessed **miniature**. Show management shall provide the log attached to a singletree.

- C. The course for snigging is a line of five cones, which must be serpentine through, both out and back. The distance between the cones is twelve feet (12'), with the start/finish line fifteen feet (15') from the first cone of the serpentine.
- D. Any gait is allowed on the course, as long as the **miniature** and the load remain in control. This is a timed event, with the fastest time winning the class. However, if any cones are stepped on or over or disturbed in any way by driver or **miniature**, a penalty of 10 seconds is added to the time for each cone moved. If a cone is moved on both the outward and the return parts of the serpentine, both incidents are penalized. Tennis balls should be used on top of cones to indicate penalties.
- E. Once across the starting line, the handler is not permitted to move the load (log). Doing so shall disqualify the entrant.
- F. The maximum weight for the log shall not exceed 50 pounds. The log shall not exceed 8 feet in length and will be 3-6 inches in diameter. Singletree is 18 inches. If more than one log is used in competition, they must match as closely as possible in size, weight and appearance.
- G. All **miniatures** must be 3 years or older for this class.
- H. Hooking and unhooking is NOT a judged part of this event. An exhibitor may have assistance getting the animals hooked and unhooked.
- I. Failure to follow pattern is a disqualification.
- J. Drivers are allowed to encourage their animals forward with voice commands or slapping of reins (but not excessively). No whips or use of ends of reins allowed. Failure to follow this rule will result in disqualification.
- K. Driver may drive from either side, change sides as necessary.
- L. Driver may go either way through the first cone.
- M. Driver **must** remain behind the animal and serpentine through cones.
- N. Attire: Standard show attire is required except exhibitors may wear any type of footwear except open-toed shoes.

### **31. Log Drag (Untimed)**

- A. The log drag consists of a log being pulled on the ground between a series of obstacles. This is not a timed event, the **miniature** may be driven at any gait. It is judged on the execution of the pattern and the ability of driver and **miniature** to work in harmony to smoothly and cleanly

navigate through the obstacles. Disturbing an obstacle or cone will be penalized.

- B. The pattern for the log drag must be posted at least one hour prior to the scheduled time for the class. Course diagrams must show with arrows the direction each obstacle must be taken. A start and finish line must be clearly established with cones or similar markers.
- C. The log drag is rigged the same as in snigging. See Rule 30 B. The log used in the log drag is as specified in Snigging Rule 30 F.
- D. It is at Show Management's discretion if Hooking and Unhooking will be a judged portion of this event. It must be indicated in the show bill.
- E. If hooking and unhooking will be a judged portion of the event then the course must be set so the contestant can return the log to its original position, turned in the correct direction for the next contestant. No headers or assistant will be allowed. ANY assistance results in disqualification.
- F. If hooking and unhooking is NOT a judged portion of this event. The driver may have assistance getting the animal hooked and unhooked without penalty.
- G. Once across the starting line, the handler is not permitted to move the load (log). Doing so shall disqualify the entrant.
- H. All **miniature**s must be 3 years or older for this class.
- I. Failure to follow pattern is a disqualification.
- J. Drivers are allowed to encourage their animals forward with voice commands or slapping of reins (but not excessively). No whips or use of ends of reins allowed. Failure to follow this rule will result in disqualification.
- K. Driver may drive from either side, change sides as necessary.
- L. Sample patterns are provided as a guide, but any workable pattern combining the required skills of maneuvering obstacles and thru cones can be used.

# Sample Log Drag #1

(OVERALL PATTERN WIDTH: ~85')

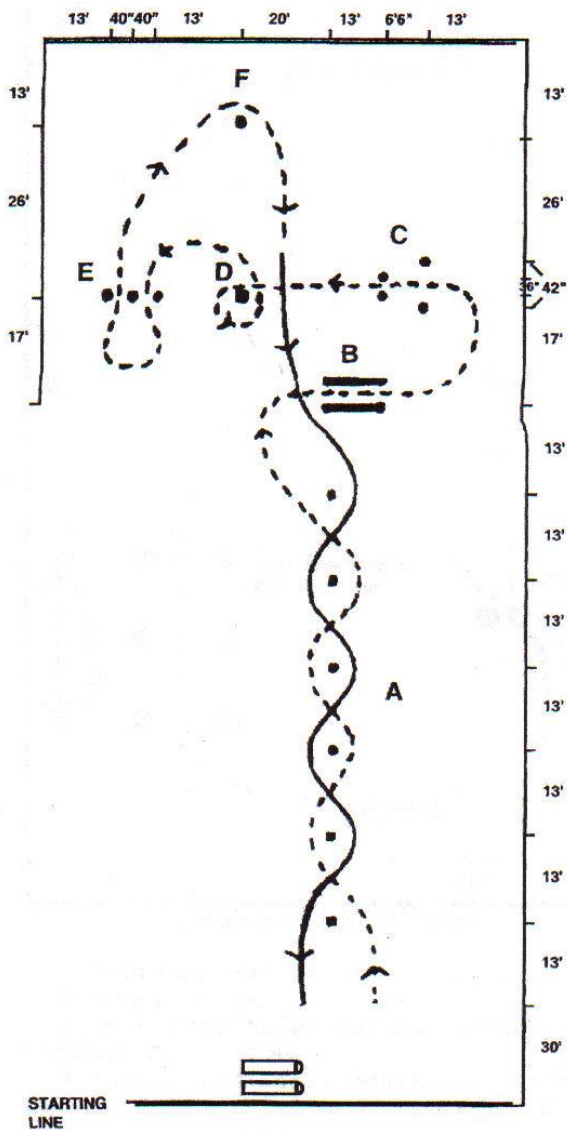

(OVERALL PATTERN LENGTH: 177')

(DISTANCE FROM ANY BOUNDARY: 13')

## Log Drag Sample #2

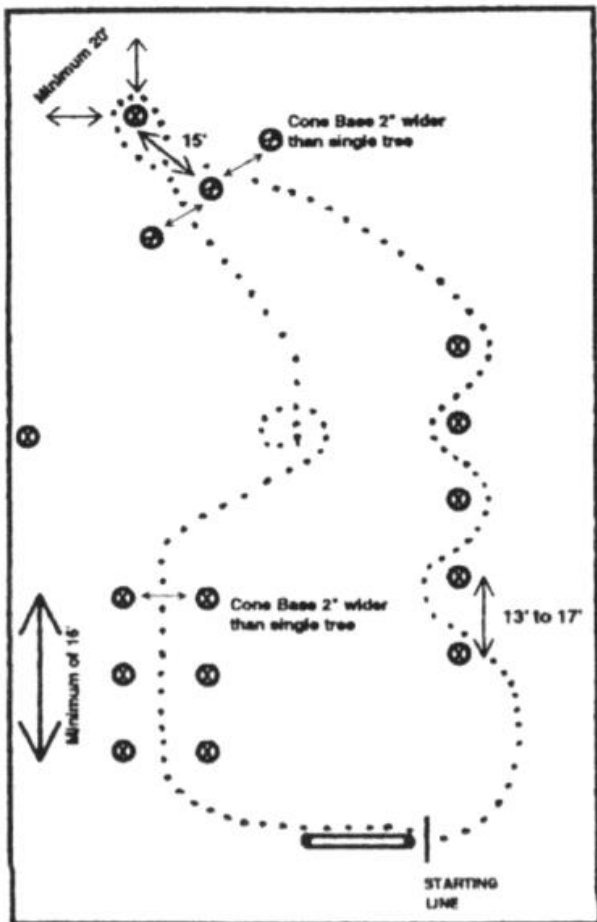

1. Hitch to log -- part of judging, no assistance
2. Weave the cones
3. Work the 180° turn around (*objective is to keep log in close proximity of cones*)
4. When even with sideline center marker, do a 360° turn either direction *without* forward movement of the log
5. Pass between cone pairs
6. Reposition log at starting line

**Pattern instructions:** Minimum Distance from any boundary: 20'  
Where noted, Pattern should be adjusted to accommodate single tree variances (Single Tree length plus 2")

## **Rules 32-39 are unassigned.**

### **40. General Driving Rules**

- A. **Miniatures** must be three years old. **Miniatures** must be serviceably sound.
- B. **Miniatures** shall compete in driving safely and securely harnessed to vehicle. The exhibitor shall be the only person permitted in such vehicle, unless more than one **miniature** is hitched to the vehicle, or the driver is a sub-youth or youth (see Rule 40 Section V for clarification).
- C. The driver must be seated comfortably in the vehicle, relaxed and effective. Either the one or two handed method of driving is acceptable. Common to both methods, the elbows and arms should be close to the body with an allowing, but steady hand enabling a consistent feel with the **miniature's mouth**. Driver should not be penalized or rewarded for using either style of driving.
- D. Drivers should keep safety foremost in their minds. Having **miniature** under control at all times not only is a safeguard for a driver, but for everyone involved in the class.
- E. All officials and show management should be constantly on the lookout for unsafe actions by any participant or unsafe harness or vehicles and report them to the Judge. The Judge must excuse from competition an unsafe vehicle, unruly **miniature** or driver clearly out of control.
- F. It is the responsibility of each driver to insure that harness and vehicle are in good repair and structurally sound.
- G. It is the responsibility of each driver to insure that his **miniature** or **miniatures** are physically fit to fulfill the tasks required of them.
- H. The driver should strive to maintain a safe distance from other vehicles both in the competition and in the warm-up and parking areas.
- I. All rules of the road should be observed unless officials direct otherwise. Drivers must drive on the rail at a safe distance behind the **miniature** and cart in front. Passing is permissible, but the driver should return to the rail as soon as possible.
- J. Boots or wraps of any description and ear plugs are prohibited on the **miniature** in the show ring.
- K. Large classes may be divided by the Judge or management when conditions warrant.
- L. Excessive use of voice, shouting, or whistling to the **miniature**, or assistance or coaching from an adult to a sub youth or

youth exhibitor should be penalized at the Judge's discretion. Discreet use of vocal aids shall be allowed.

- M. All pleasure driving vehicles must have a basket or safe suitable floor. Sulkies are allowed in Obstacle Driving classes and game driving classes only.
- N. Wire wheeled and pneumatic tired wheels are permitted in all driving classes.
- O. Drivers should strive to present appropriate turnout. "Appropriate" indicates the balance and pleasing appearance of the combination of **miniature** and vehicle.
- P. Harness may be of collar or hames type or breast collar type. Martingales, over checks, side checks, and blinders are optional. Cavessons or nosebands are required. Thimbles, shaft stops, or breeching are required.
- Q. The whip must be carried in driver's hand at all times. The overall length of the whip for a single **miniature** should be long enough to reach its shoulder. Driver shall be penalized for excessive use of the whip.
- R. Snaffle bits, curb bits, and other types of traditional driving bits are allowed. If a curb bit is used, the chain must meet the Judges approval and lie flat against the jaw of the animal. Bits may be covered with leather or rubber. Twisted, burr and wire bits of any type are not permitted. Tying down of tongues is prohibited.
- S. Attire: Gentlemen are to wear a hat, coat, vest, or jacket, and tie. Ladies are to wear dress, tailored suit, skirt or pants with blouse, vest or jacket, and hat. Gloves are optional for all driving classes. Lap robes for men and women are optional. Any period costume may be worn that is related to and appropriate for the vehicle being driven. If female exhibitor is attired in a short dress a lap robe is required. Short sleeves may be worn with any period attire. Hard hats with a chin strap for all youth and sub-youth drivers (age 18 and under) are strongly recommended, and will not be penalized, and are optional for drivers over age 18.
- T. Canter is not allowed in any driving class. **Miniatures** must stay at a walk or trot. Depending on the class it could be a penalty or a disqualification.
- U. **AUTOMATIC DISQUALIFICATION:** Anywhere on the show grounds, the failure to have a header in place when driver is not in the vehicle, or the removal of a bridle while the animal is still between the shafts will result in automatic and **IMMEDIATE** disqualification.
  - 1. Driver may exit vehicle and head his/her own animal.
  - 2. Do not tie hitched animal and leave unattended.

- V. Sub-Youth drivers under 10 years of age **MUST** be accompanied in the vehicle by a knowledgeable adult. Adult **MAY** ride in vehicle driven by a youth 11 years and older. Adult must comply with dress code.
- W. If an adult in any way assists sub-youth or youth exhibitor, the exhibitor will be automatically disqualified, but will not be immediately excused from the arena by the judge.
- X. Should a breakdown occur during a competition, the exhibitor shall have 5 minutes to make necessary repairs, after which time exhibitor will be excused from the show ring. Should a breakdown occur on the way to the arena, the exhibitor shall have 5 minutes to make repairs, after which, if repairs have not been made, the exhibitor is excused from entry.
- Y. In all classes, fancy equipment not to count over neat, suitable working outfit.
- Z. Measurements for all driving events must be the **inside clearance** not measured from the center of the obstacle (I.e. cone, pole, barrel, bale of hay, etc.).
- AA. Reversals - In all driving classes, reversals must be at a walk and will be made on the diagonal at the direction of the Ring steward only. The correct way to reverse is shown in the drawing below.
- BB. Fall of animal or rider will result in disqualification.
- CC. No Headers allowed, except for emergency situations.

### Correct Way to Reverse

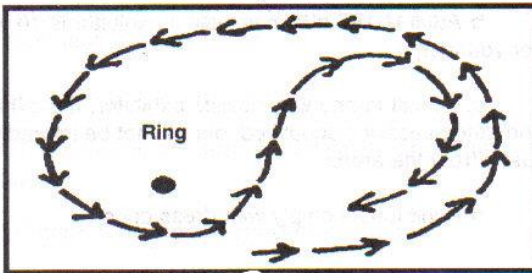

#### **41. Clarification of Pleasure Driving Gaits**

- A. Walk - A free, regular and unconstrained walk of moderate extension is required. The **miniature** should walk energetically, but calmly, with an even and determined pace.
- B. Slow Trot (Park Gait) - Should maintain forward impulsion while showing submission to the bit. It is slower and more collected, however the **miniature** should indicate a willingness to be driven on the bit while maintaining a steady cadence.
- C. Working Trot (Road Gait) - The **miniature** goes forward freely

and straight; engaging the hind legs with good hock action; on a taut, but light rein; the position being balanced and unconstrained. The footsteps of the hind feet touch the ground in the foot prints of the fore feet.

- D. Halt - **Miniature** and vehicle should be brought to a complete square stop without abruptness or veering. At the halt, **miniature** should stand attentive, motionless and straight with the weight evenly distributed over all four legs and ready to move off at the slightest cue from the driver.
- E. Rein Back - A backward movement in which the legs are raised and set down simultaneously in diagonal pairs with the hind legs remaining well in line. To be performed in two parts; The **miniature** must move backward at least four steps in an unhurried manner with head flexed and straight, pushing the vehicle back evenly in a straight line. The driver should use quiet aids and light contact. The **miniature** must move forward willingly to former position using the same quiet aids.

#### **42. Performance Driving Classes - Pleasure Driving Working**

- A. A pleasure driving class in which entries are judged primarily on the suitability of the **miniature** to provide a pleasant drive.
- B. To be shown both ways of the arena at a walk, slow trot, and working trot. To stand quietly and rein back.
- C. **Miniatures** shall enter arena to the right at a slow trot.
- D. Judge may request a workout of chosen entries and exhibitors may be asked to work at any gait, as described above, and may be asked to execute a figure eight.
- E. Judged as follows:
  - 1. 90% performance, manners and way of going of **miniature**
  - 2. 10% condition and fit of harness and vehicle and neatness of attire

#### **43. Performance Driving Classes - Pleasure Driving Reinsmanship**

- A. Entries are judged primarily on the ability and skill of the driver.
- B. To be shown both ways of the arena at a walk, slow trot, and working trot. Driver shall be required to rein back.
- C. All drivers chosen for a workout may be worked at any gait requested by the judge and may be asked to perform other appropriate tests.
- D. The judge may call the class with specific direction or a pre-

determined pattern may be used. If a pre-determined pattern is used it must be posted at least one hour prior to the scheduled time of the class.

- E. Judged as follows:
  - 1. 75% handling of the reins and whip, control, posture, and overall appearance of driver
  - 2. 25% condition of harness and vehicle and neatness of attire.

Rules 44-49 are unassigned.

## **50. Performance Driving Classes - Obstacle Driving (non-timed)**

- A. The Obstacle Course must be posted at least one hour prior to the scheduled time of the class.
- B. Class to be judged on performance and way of going with emphasis on manners throughout the course. Entries will be evaluated on responsiveness and willingness, plus general attitude.
- C. An exhibitor has sixty (60) seconds or three refusals whichever comes first to complete each obstacle. After time is used or the three refusals has occurred, the exhibitor will be directed to the next obstacle. Refusals do not constitute class disqualification.
- D. Canterng must be penalized in this (non-timed) class.
- E. Obstacle requirements:
  - 1. Must be a minimum of five (5) obstacles and a maximum of eight (8).
  - 2. Care must be used to avoid setting any obstacle in a way so as to be hazardous to the **miniature** or exhibitor.
- G. Drivers will be allowed five (5) minutes to walk the course prior to the start of the event and inspect each obstacle. While walking the course, drivers shall not alter, adjust or in any way move an obstacle or any part thereof. Pattern discrepancies should be brought to the Ring steward or course designer's attention for clarification.
- H. Drivers are prohibited from driving or leading **miniatures** on course at any time prior to the competition. Non-compliance will result in elimination.
- I. Suggested widths for obstacles are 8" to 20" wider than the widest permanent part of the vehicle usually the rear axle of the largest vehicle.
- J. The Judge will assign a point value to each obstacle and

points will be added to or subtracted from this score based on the **miniature**'s performance through the obstacle.

- K. Credit will be given to those **miniatures** who negotiate, in a continuous motion, the obstacles cleanly, smoothly and alertly with style in prompt response to the driver's cues. Excessive hesitation at an obstacle will be penalized.
- L. A **miniature** with major faults (knockdowns, refusals, etc.) on the course will not be placed ahead of a **miniature** that worked through the obstacles cleanly. A **miniature** should be penalized for the touching of any elements on the course and for unnecessary delay in approaching the obstacles.
- M. Off Course:
  - 1. Deviating from the prescribed order in which the obstacles are to be approached.
  - 2. Taking the obstacles from the wrong direction.
  - 3. Skipping an obstacle unless directed by the Judge.
- N. The course shall be designed to require each **miniature** to demonstrate the walk, trot and back somewhere between the obstacles as part of the working course with enough space provided for the Judge to evaluate the gaits.
- O. The **miniature** is judged on the ease with which it maneuvers the obstacles. Knocking over an obstacle or part of an obstacle, breaking gait and disobedience are to be considered penalties. Breaking the pattern, being off course, outside assistance, , failure to carry a whip, and use of a tie down result in elimination.
- P. Suggested Obstacles:
  - 1. Back through or out of obstacle
  - 2. Drive through water or simulated water
  - 3. Drive through narrow passage
  - 4. Stop, open and close mailbox
  - 5. Drive across bridge or simulated bridge
  - 6. Drive pattern created with poles, pylons (figure 8, serpentine, cloverleaf, etc.)
  - 7. Put wheel in circle, turn complete circle with **miniature** not stepping in circle
  - 8. U-Turn (a 3 rail box with a pylon in center of opening)
- Q. Prohibited Obstacles:
  - 1. Live animals or hides
  - 2. Driver dismount
- R. The Judge has the right to alter the course for time and/or safety.

## **51. Performance Driving Class - Gambler's Choice (timed event)**

- A. A timed driving course of unnumbered obstacles each carrying a specific assigned point value. Each driver has the same amount of time to negotiate as many obstacles as possible. Each obstacle is assigned a point value according to its degree of difficulty and each driver tries to amass as high a score as possible within the time allowed.
- B. Canter is not permitted. There will be a five point penalty for each stride a **miniature** breaks into a canter with a disqualification after the fourth stride.
- C. After passing through the starting line, the driver may drive through the obstacles, in any order, from any direction. Each obstacle may be driven twice, but not in succession. If driven a third time, no points will be awarded.
- D. No obstacle may be re-driven once it has been disturbed. (Exception: obstacles which are designed to be knocked down). No points will be awarded for an incorrectly completed obstacle. If obstacle is incorrectly driven, but not disturbed, it may be attempted again.
- E. If a **miniature** should refuse or run-out at an obstacle without disturbing it, the driver may elect not to attempt it and may drive to another obstacle without penalty. The obstacle may be attempted later, and if correctly driven, the appropriate points will be recorded.
- F. A signal will sound 30 seconds before the end of the allowed time to alert the driver. A second signal will sound at the end of the allowed time. Drivers that have not exited through the finish line must exit and their total time will be recorded. Recorded time over the allowed time will be penalized.
- G. If the signal sounds when the driver is committed to an obstacle, the competitor may complete the obstacle and receive the appropriate points, then proceed through the finish markers for total time to be recorded. Whether or not the competitor was committed to the last obstacle at the signal will be left to the discretion of the judge.
- H. Placings are determined on a high score basis. Time will decide ties. If a tie occurs in points and time, the tie will be decided by a drive-off.

# Examples of Obstacles for Driving Classes

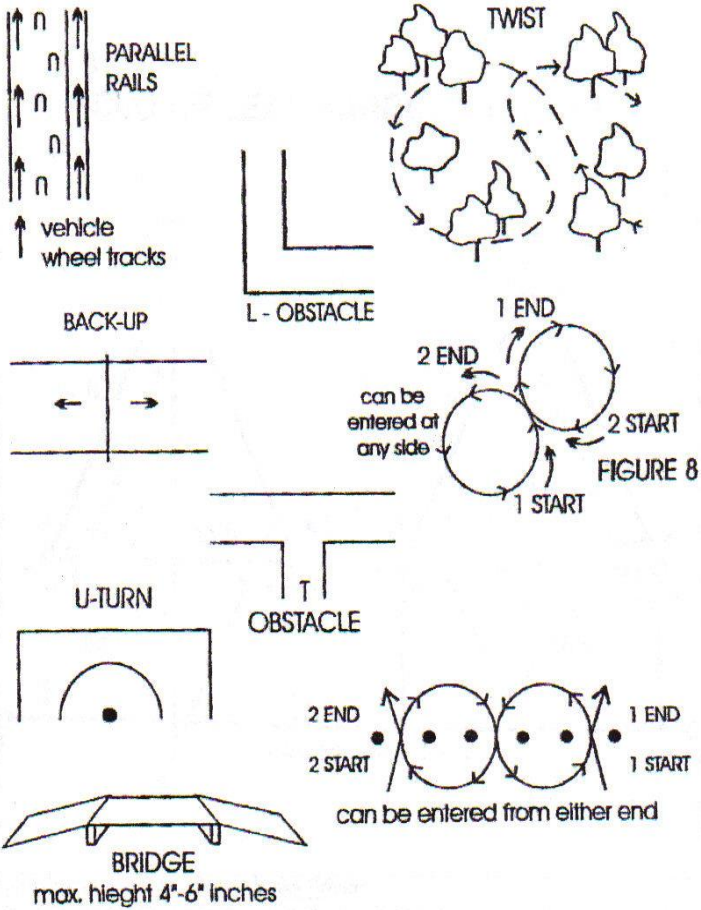

## **52. Game Driving Classes - Cloverleaf Barrel Driving**

- A. Three barrels shall be placed to form an equilateral triangle.
- B. This is a timed event, with the fastest **miniature** and driver determined the winner. Knocking over a barrel will constitute a five second penalty for each barrel knocked over. Touching a barrel is permitted.
- C. Contestants shall be disqualified for not following the pattern. Canter is not permitted. There will be a five (5) second penalty for each time a **miniature** breaks into a canter with a disqualification on the 3<sup>rd</sup> time or if the animal canters more than 4 strides.
- D. Course shall be measured with a measuring tape.
- E. Timing line shall be 50 feet from both barrels #1 and #2.
- F. The distance from barrel #1 to barrel #2 shall be 50 feet.
- G. The distance from barrel #1 to barrel #3 shall be 50 feet, and also from barrel #2 to barrel #3 it shall be 50 feet.
- H. The barrels may be run either direction as shown in the diagram.
- I. Sample #1 - Entry shall cross the starting line, circle barrel #1 clockwise, circle barrel #2 counter-clockwise, circle barrel #3 counter-clockwise, and drive back, between #1 and #2, across the timing line.
- J. Sample #2 (reverse order) - Entry shall cross the timing line, circle barrel #2 counter-clockwise, circle barrel #1 clockwise, circle barrel #3 clockwise, and drive back, between #1 and #2, across timing line.

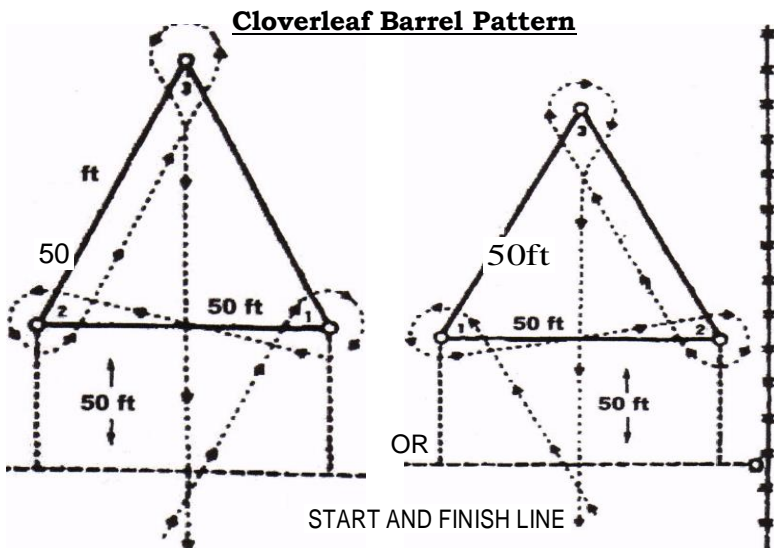

### **53. Game Driving Classes - Single Stake Driving**

- A. One single stake (pole) is placed approximately in center of arena, with two timing stakes or cones near entrance or end of arena representing the timing line.
- B. This is a timed event, with the fastest **miniature** and driver determined the winner. Knocking over the stake will constitute a five second penalty. Touching the stake is permitted.
- C. Contestants shall be disqualified for not following the pattern. Canter is not permitted. There will be a five (5) second penalty for each time a **miniature** breaks into a canter with a disqualification on the 3<sup>rd</sup> time or if the animal canters more than 4 strides.
- D. The timing line markers shall be 20 feet apart. The distance from the timing line shall be 100 feet to the stake. The distances may be reduced to fit the arena.
- E. Course shall be measured with a tape.
- F. The course shall be run as in diagram. Contestants shall cross between timing stakes, proceed to single stake, go around stake and return through timing stakes. The contestants may turn either right or left around the stake.
- G. This class is run individually. Only one **miniature** and driver on the course at a time.

timing line

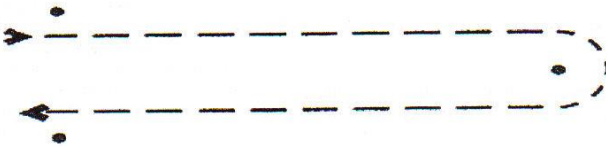

### **54. Game Driving Classes - Keyhole Driving**

- A. The course shall be laid out with a limed keyhole pattern on the ground. The throat of the keyhole shall be perpendicular to and facing the timing line, with the center of the circle 50 feet from the timing line.
- B. The keyhole shall be in the form of a broken circle 20 feet in diameter, with a throat 4 ½ feet wide inside the white line, and 10 feet long.

- C. This is a timed event, with the fastest **miniature** and driver determined the winner.
- D. Course shall be measured with a tape.
- E. **Miniature** shall cross the timing line, enter the circle of the keyhole, turn around in either direction, entirely within the circle of the keyhole, exit through the throat, and re-cross the timing line.
- F. The **miniature** shall be disqualified for stepping on or out of any line of the keyhole (or if vehicle wheel is on or over the line).
- G. It is show management's responsibility to keep all limed lines visible at all times. Course should be raked and re-limed when line was fouled.
- H. Contestants shall be disqualified for not following the pattern. Canter is not permitted. There will be a five (5) second penalty for each time a **miniature** breaks into a canter with a disqualification on the 3<sup>rd</sup> time or if the animal canters more than 4 strides.

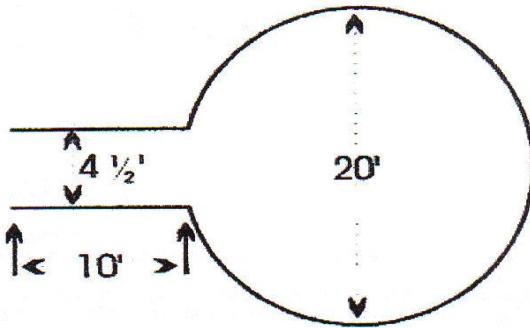

**55. Game Driving Classes - Pole Bending Driving**

- A. Five stakes (poles) are in a straight line, there are two cones at the entrance to represent the timing line.
- B. This is a timed event, with the fastest **miniature** and driver determined the winner. Knocking over a pole will constitute a five second penalty for each pole knocked over. Touching the pole is permitted.
- C. Contestants shall be disqualified for not following the pattern. Canter is not permitted. There will be a five (5) second penalty for each time a **miniature** breaks into a canter with a disqualification on the 3<sup>rd</sup> time or if the animal canters more than 4 strides.

- D. The distance between the base of the poles shall be 12 feet. The distance between the first base of the pole and the timing line is 20 feet.
- E. Course shall be measured with a tape.
- F. The course shall be run as in diagram. Contestants shall cross between timing markers/cones, start either right or left, weaving in and around each pole. Weave back in and around each pole and cross timing line.
- G. This class is run individually. Only one **miniature** and driver on the course at a time.

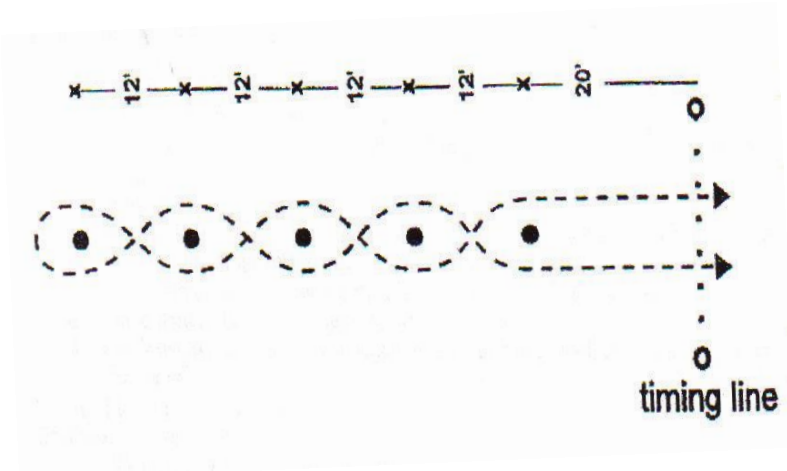

**Rules 56-69 are unassigned.**

### **70. In-Hand Trail**

- A. **Miniatures** to be shown while being led at a walk and trot from the ground. Not to be asked to lope.
- B. The course must be posted at least one (1) hour prior to the scheduled time of the class.
- C. Class to be judged on performance and way of going with emphasis on manners throughout the course. Entries will also be evaluated on responsiveness and willingness, plus general attitude.
- D. An exhibitor has sixty (60) seconds or three refusals whichever comes first to complete each obstacle. After time is

used or the three refusals have occurred, the exhibitor will be directed to the next obstacle. Refusals do not constitute class disqualification.

- E. Obstacle requirements - There must be a minimum of five (5) obstacles and a maximum of eight (8).
- F. Care must be used to avoid setting any obstacle in a way so as to be hazardous to the **miniature** or exhibitor.
- G. Tires and stair steps are prohibited.
- H. Jumps, if used, must be a maximum of twelve (12) inches high and a minimum length of five (5) feet. Jumps must include ground poles. In classes where animals are under 3 years of age jumps cannot exceed six (6") inches.
- I. In shows where open, green, pre-green, and youth classes are offered, at least three (3) obstacles must be different or the manner or performance through obstacles must be varied for the classes.
- J. No edible treat to encourage a **miniature** to perform an obstacle is allowed.
- K. Equipment required: **Miniatures** shall be shown in a correctly fitted halter and adjusted for said **miniature**. Lead rope or lead rope with chain shank (chain optional except for jack 2 years old and older). Jacks 2 years and over must be shown with chain shank or rope under chin or stud bridle. Equipment must be humane and in good condition. Silver not to count. Optional equipment: Pack saddle.
- L. Obstacle guidelines -- The course designer should be readily available to answer questions regarding the course and be available for a walk through the course with the exhibitors as well as the Judge. Ingenuity and originality in adapting and combining various obstacles both to demonstrate a **miniature's** willingness and ability to please exhibitor and the audience are encouraged. However, unnatural or "horror" obstacles should be avoided and all obstacles should be safe for exhibitors as well as **miniatures**. The Judge has the right to alter the course for time and/or safety.
- M. It is recommended that when different divisions are offered (I.e. pre-green, green, and open) the requirements should match the division and increase in difficulty from lowest (pre-green) to highest (open). The course designer should consider the level of difficulty and the most logical progression of training.
- N. Suggested Obstacles:
  - 1. Back-up through or out of obstacle
  - 2. Walk through water or simulated water

3. Put on or remove equipment (raincoat, saddle, or pack saddle, etc.) from exhibitor or **miniature**
4. Walk through narrow passage
5. Pick up object (letter, umbrella, bucket, etc.) and return or carry to designated location
6. Walk or trot across bridge or simulated bridge
7. Walk or trot pattern created with poles, pylons (figure 8, serpentine, etc.)
8. Stand **miniature** in circle, ground tie, walk around **miniature**
9. Side-pass (either or both directions), pick up one or all feet, ground tie, and walk or trot overs
10. Stop and clean or check hoof

O. Off-Course is defined as:

1. Taking an obstacle in the wrong direction
2. Negotiating an obstacle from the wrong side
3. Skipping an obstacle unless directed from the judge
4. Negotiating obstacles in the wrong sequence.

Note: Off course will result in elimination

# Suggested Trail Obstacles

## BACK THROUGH AND AROUND THREE MARKERS

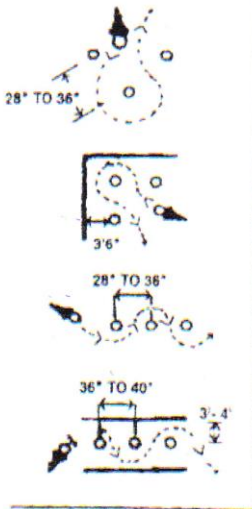

## VARIATIONS OF L BACK THROUGH

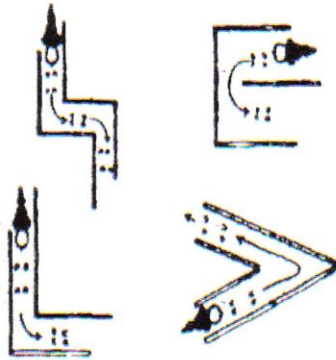

## VARIATIONS OF SIDEPASS

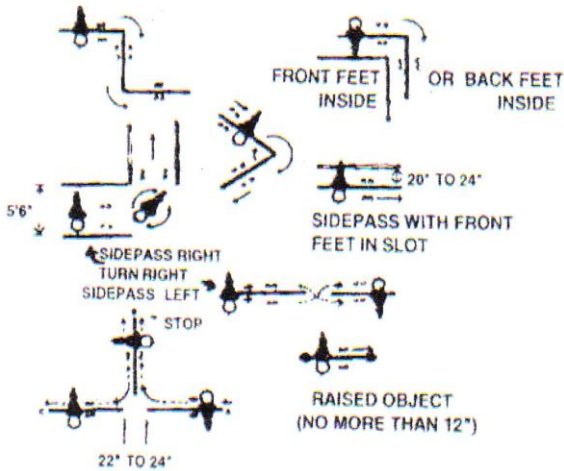

## **71. Versatility Class**

- A. Versatility is designed to show the qualities and abilities of a **miniature** 3 years or older in three distinctive disciplines: Driving, Halter, and Jumping. Versatility may be offered as a point earning class or may be offered as a separate Championship.
- B. The three elements in versatility will always be in the order of Driving, Halter, and Jumping.
- C. Each entry must have a groom/header to assist handler immediately following the driving element.
- D. Each entry will enter the ring to the right on the rail at a trot in a driving rig. Pleasure driving rules will apply.
- E. Once the driving element is completed, and drivers come into their line-up, grooms/headers will be called or signaled to come into the ring. Grooms/Headers must be dressed neatly and may wear smocks to cover any farm identification. Shorts, open-toe shoes or t-shirts are not allowed. Two (2) minutes will be allowed for untacking and grooming.
- F. Before competitors are allowed their 2 minute untacking and grooming prep, it shall be announced that the **MINIATURES ARE TO REMAIN IN THE SAME ORDER FOR THE REST OF THE CLASS AS THEY GO ON THE RAIL, BOTH FOR THE HALTER AND JUMPER PORTIONS.**
- G. At the end of the two minute period, grooms/headers shall leave the arena with the carts and all tack, and handlers with their **miniature** are then asked to follow the direction of the Ring steward as they line up for inspection at Halter.
- H. When halter inspections are completed, the entries again follow the Ring steward in the same order and proceed to the Jumping course. The Jumping requirements for judging, faults, eliminations, and fences are to meet the same requirements as specified under the In-Hand Jumping Rules except there will be a minimum of 2 and maximum of 4 jumps.
- I. There will be only one untimed round.
- J. When all have completed the jumping course the **miniatures** must trot for soundness before the Judge.
- K. **Miniature** do not leave the arena between elements.
- L. All three elements to count equally. **Miniatures** must **compete in all three elements, without disqualification**, to be eligible for awards and or points.
- M. Failure to have **Miniature** un-harnessed and ready for the inspection at halter within the two minute time limit will result in disqualification.

**Rules 72-79 are unassigned**

## **80. Showmanship**

- A. In a Showmanship class, only the exhibitor shall be judged. The **miniature** is only a prop to show the ability of the exhibitor but will be considered for appearance as per #C-1 (below).
- B. The Show Management must post the pattern for the Showmanship Class(s) at least one hour before the class is to be held.
- C. Scoring to be as follows:
  - 1. Appearance of **miniature** - 40%  
(Overall cleanliness, grooming, condition of hooves, halter and lead should be neat, clean and in good repair)
  - 2. Appearance of Exhibitor - 10%  
(Handler's attire neat and appropriate for the show ring; hat, boots are required for this class. Failure to comply will result in a penalty by the Judge. Gloves are recommended but not required.)
  - 3. Presentation of the **miniature** in arena - 50%  
(Ability to lead, posing the **miniature**, following posted pattern, alertness of exhibitor)
- D. Whips are not allowed in Showmanship classes.
- E. Leading - Walk on **miniature**'s left side, holding the lead in the right hand, near halter. The remaining portion of lead is held neatly and safely in the left hand. A tightly coiled or rolled lead shank will be considered a fault in Showmanship. The **miniature** should lead readily at a walk or trot. The **miniature** should not follow behind, nor in front of exhibitor, but rather lead along side of exhibitor.
- F. When posing the **miniature**, stand toward the front facing the **miniature**, but not directly in front of the **miniature** and always in a position where you can keep your eye on the Judge. Pose the **miniature** with its feet squarely under it. Do most of the showing with the lead strap. Never kick a **miniature**'s leg into position or move its legs by hand.
- G. Do not crowd the exhibitor next to you when in a side-by-side position. Do not crowd the exhibitor in front when lined up head to tail.
- H. When judge is observing other **miniatures**, let your **miniature** stand if posed reasonably well.
- I. Be natural. Over showing, undo fussing, and maneuvering are objectionable.
- J. Show the animal at all times, not yourself.
- K. Respond quickly to requests from judges and officials.
- L. Be courteous and sportsmanlike at all times.

- M. Recognize quickly and correct faults of your **miniature**.
- N. Keep showing until the entire class has been placed and excused from the ring.
- O. A Judge may ask exhibitor questions (optional) exhibitor number, parts of **miniature**, age and so forth.
- P. A judge may ask an exhibitor for additional tests at his or her discretion upon completion of the pattern.

### **81. Instructions for Showmanship Sample Pattern #1**

- A. Walk to the Judge in a straight line.
- B. Stop and set up your **miniature** for inspection. See Rule 83.
- C. Upon acknowledgement from the Judge, do a 180 degree turn. (All turns are to be to the right)
- D. Trot in a straight line - past the line up - stop.
- E. Do a 180 degree turn.
- F. Walk the **miniature** forward to the exact spot in the line up, where you were when you started the pattern, and set up your **miniature**.
- G. This pattern shall always be used for Sub-Youth Showmanship classes.

### **82. Instructions for Showmanship Sample Pattern #2**

- A. Walk toward the Judge in a straight line
- B. Stop half way between the line up and Judge and do a 360 degree turn - stop. (All turns are to be to the right)
- C. Continue at a walk toward the Judge in a straight line.
- D. Stop and set up your **miniature** for inspection, See Rule 83.
- E. Upon acknowledgement from the Judge, do a 180 degree turn.
- F. Trot in a straight line, past the line up, stop.
- G. Do a 180 degree turn.
- H. Walk your **miniature** forward to the exact spot in the line up, where you were when you started the pattern, and set up your **miniature**.

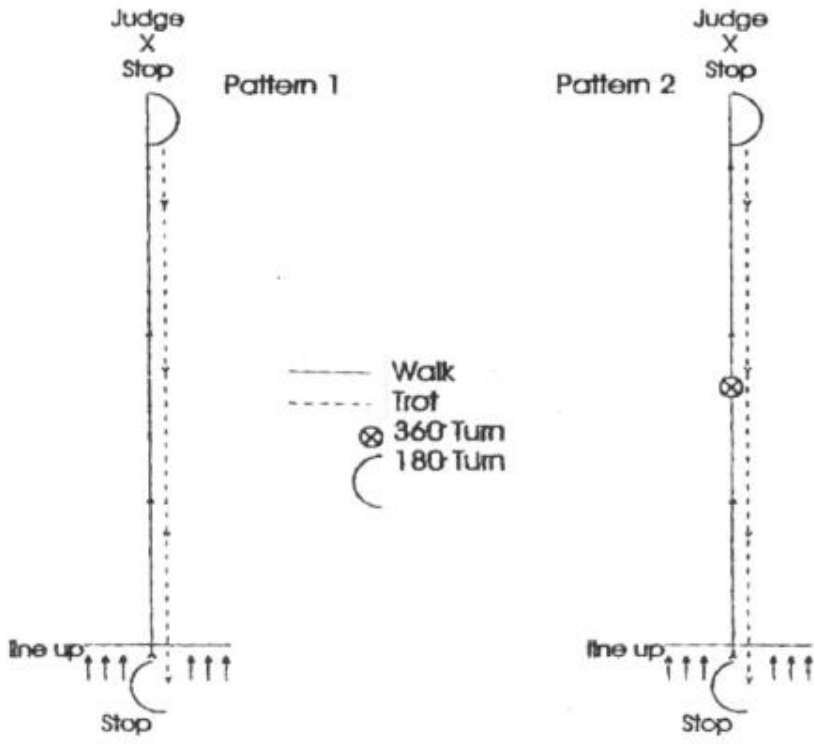

**83. Proper Position of Handler and Animal During Showmanship Inspection.**

- A. When posing your **miniature**, stand toward the front facing the **miniature** but always in a position where you can keep your eye on the judge. The following Quarter System will be used whereby imaginary lines bisect the **miniature** into four equal parts as seen in the illustration (Note: the quadrants are numbered I, II, III, and IV for ease of identification). One line runs across the **miniature** just behind the withers. The other imaginary line runs from head to tail. The exhibitor should lead the **miniature** straight to the judge so the judge can evaluate the **miniature**'s front leg movement. Once the **miniature** is safely located in front of the judge, the **miniature** should be squarely set up for inspection and the exhibitor then locates in the proper position in quadrant IV. As the judge moves to quadrant I the exhibitor shall stay in quadrant

IV. When the judge moves to quadrant II the exhibitor then moves to the proper position in quadrant I. When the judge moves to quadrant III the exhibitor moves back to quadrant IV. As the judge moves to quadrant IV the exhibitor once more moves to quadrant I. The exhibitor should never stop in the unsafe location directly in front of the **miniature**. When the judge returns to his position in front of the **miniature** the exhibitor should return to quadrant IV and await instructions from the judge. When released by the judge the **miniature** should be pivoted directly in front of the judge and move away in a straight line so the judge can observe the **miniature**'s rear leg movement. Other patterns maybe used where the **miniature** does not leave the judge in a straight line.

- B. This system results in the exhibitor always being in a safe position, the exhibitor always being able to see the Judge and the **miniature**'s position, the exhibitor always being in a position to keep the **miniature**'s hindquarters from swinging toward the judge should the **miniature** become fractious and unsafe for the judge, and the judge being in a safe position at all times to evaluate the exhibitor's ability to show the **miniature** as desired.

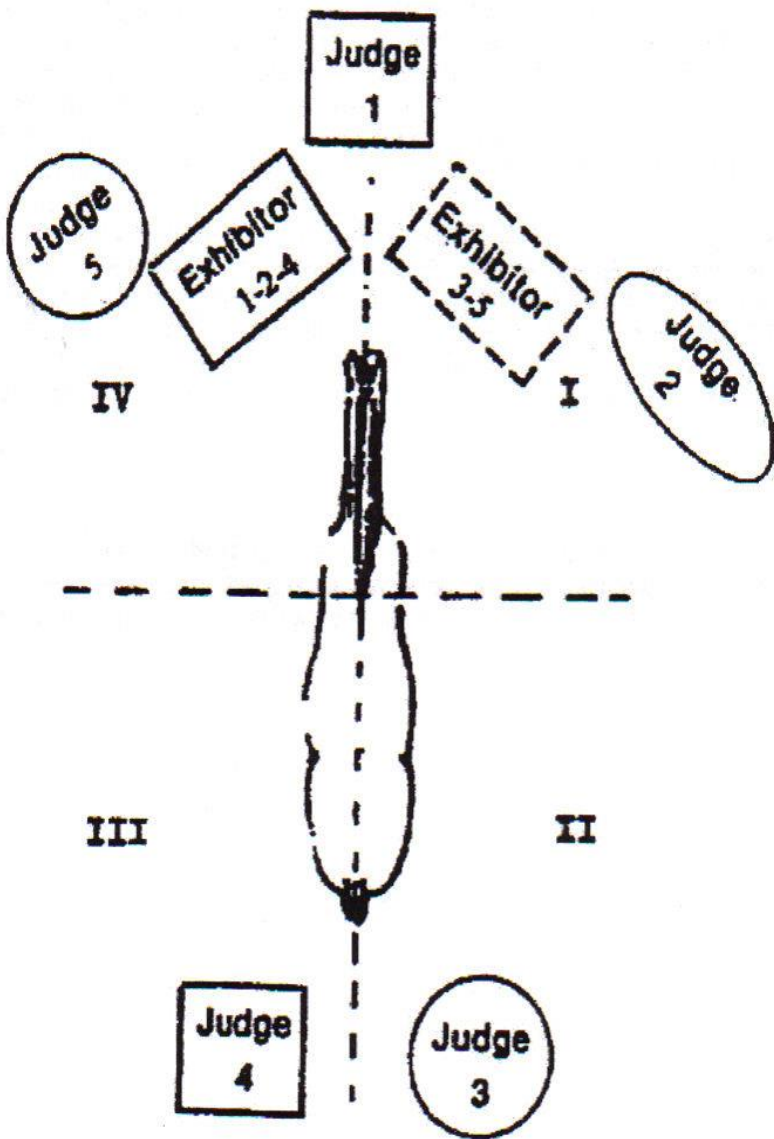

Rules 84-89 are unassigned.

## **90. Pee-wee Division**

- A. This division is specifically designed for our Pee-wee competitors. See Rule 3D for age of exhibitors.
- B. This class is geared toward encouraging Pee-wees to show their **miniatures** in a fun manner.
- C. This division shall include leadline class, showmanship at halter, trail or a combination of classes at show management's discretion.
- D. The Judge will participate in the class, but each exhibitor will receive an equal award. Placement of participants is not allowed in Pee-wee class.
- E. Each exhibitor must have an adult in the ring with them at all times.

## **91. Costume Class**

- A. Costume classes are to be judged 75% on originality of costume and 25% on presentation.
- B. To be shown at a walk both ways of the arena.
- C. This costume class is intended for the exhibitor who creates an unusual, perhaps funny costume for the **Miniature** and exhibitor.
- D. Exhibitor may lead or drive the **miniature**.
- E. Each entry in this class MUST be accompanied by a typed or legibly written description to be read by the announcer. It is suggested that show management place a time limit of two minutes on each entry's entire costume presentation. If a time limit is chosen, it must be stated on the show bill so contestants have time to correctly prepare their presentation. Show management must also be sure to have a time keeper available to keep track of each entry's time. Failure to adhere to any stated time limit will remove that entry from award consideration.
- F. The written description and any taped music should be given to the show representative at a time specified in the show bill or announced at the show so management will have time to read and assemble the information to exhibitor's best interest. Since no costume information will be taken after the appointed time, the exhibitor may elect to show without script/tapes or withdraw from the class with no refund of entry fee(s).
- G. Any number of people or props may be used to make up a costume, however, all participants must be in related costume.

H. Open to all age exhibitors.

## **92. Additional Classes**

1. Show management may at its discretion add classes so long as the rules of the class are provided to the exhibitors and the judges. Additional classes need to be within the abilities of the **miniatures** and be safe for both the animal and the handler

(Due to formatting issues, pages listed may be one page off)

# Index

- Abuse 7, 66, 84, 107, 112, 127, 137
- Adult 9,17,18, 39, 45, 56, 58, 59, 60, 66, 106, 120, 140, 144, 181
- Adult "sponsor" 97
- Additional Classes 185
- Amateur 22
- AQHA 7, 8, 22, 72-76
- Arena conditions 12, 68
- Attire 22, 25, 26, 27, 43, 48, 106, 120, 142, 151, 154, 158
- Assistant 52, 58, 59, 88, 106, 124, 137, 144, 152, 153, 158
  
- B
- Baseball Race. See Potato Race 117
- Beginner Adult 24
- Bits
  - Cattle Classes 34
  - Driving 35
  - English Performance 29
  - illegal 37
    - pictures 34
  - Miniature driving 163
  - Pictures - English 33
  - Pictures - Western 32
  - Speed Events 34
  - Western Performance 27
- Blind bridles 27
- Boot Race 120
- Braiding 34
- Breakdown
  - Driving classes 44,164
  - Hunter (scoring) 99
  - Jumping classes (scoring) 99
- Breeching 35,163
- Buffalo Hunt 128

## C

Canter 16, 43, 45-47, 50, 67, 82, 89, 90, 94, 96-99, 102, 110, 156, 163, 166, 168-172

Cattle Classes 30, 35, 36, 164,

Cavesson nosebands 25, 30, 154

Driving-optional 36

English Performance-required 30

Flash Cavesson 35-prohibited

Western Performance-prohibited 30

Miniature Driving - required 164

Class call 9

Class Rules

Barrels 115, 171

Cattle Classes 129

Driving 44, 153

English Performance 96

Halter 37, 150

Log Dragging 54

Mule Pulls 137

Ranch Riding 92

Showmanship 40, 168

Specialty Performance 109

Timed Events 10, 11, 13, 114, 143

Western Performance 56

Command Class 90

Complaints, See also Protests 15

Controlled substance 14

Coon Hunters Jumping 109, 154

Costume Class 110, 183

Curb chain 28, 29, 36, 68,

## D

Definitions 15

Diagonals (English) 99

Disqualifications

Automatic 44, 164

Immediate 10

Donkeymanship 83

Draft mule 16, 38, 53  
Driving Classes 27, 36, 44, 164-170  
Attire 27, 166  
Equipment 36, 45, 50, 165

## E

Egg In Spoon Ride 121  
Egg Race 120  
English Performance Classes 26  
English Pleasure 27  
Entries 10  
Entry Number 10, 150, 151  
Equipment 28  
Driving 36  
Halter Classes 28, 175  
Speed Events 35  
Western Performance Classes 28  
Exceptional attire 27  
Exotic mule 15  
Extended trot Driving 44

## F

Fence heights  
Hunter Hack  
Jumping 97, 98  
Working Hunter 101  
Flag Race 120  
Freestyle Reining 108 See also Reining

## G

Gaits 14  
Driving 44, 165, 168  
English Performance (except Eng Pleasure) 100  
Western Performance 16, 84, 85, 86, 92, 93  
Gambler's Choice Driving 50, 56, 148, 169  
Gambler's Choice Trail 125  
Gates 12  
Gloves 27, 35, 36, 122, 144, 164, 179

Green 9, 19, 20, 21, 22, 25, 28, 46, 47, 56, 57, 59, 60,  
67, 68, 83, 93, 96, 101, 103, 136, 142, 143, 146,  
148, 149, 157, 175,  
Gymkhana. 12, 13, 21. Also See Speed Events

## H

Hackamore 28, 35  
Halter Classes 7-9, 12, 15, 19, 28, 37-40, 145-152  
Get of Sire 39,148,151  
    Matched Pairs 13, 39, 148, 152  
    Model/Reserve Model 39,146  
    Produce of Dam 39,148,151  
Hand gallop 96, 100  
Hard hat 27 --See also Protective head gear  
Hearing Committee 7, 140, 142  
Height classifications  
    Donkeys 38  
    Mules 38  
Hide Drag 122  
High Point 8, 12, 13, 19, 21,142,145  
Hinny 15  
Hunt Seat Equitation 98  
Hunter Hack 4, 97  
Hunter Under Saddle 4, 27, 96  
Hurdle Race 121

## I

Illegal Bits 3, 37

## J

Jackpot pay schedule 13  
Jacks 10, 19, 38, 67, 109, 110, 141, 145, 147, 150, 156, 175  
Jog 16, 44  
Judge 7, 8, 10, 11, 35,  
Jumping 26, 30, 35, 99, 101, 102, 103, 105, 106, 109, 121,  
143, 152, 154  
Jumps, (See Fence heights) 62, 97, 98, 102, 103, 121, 143,  
152, 157, 175

## K

Keyhole Race 118, 172

## L

Lap robes 27, 36, 164

Lead Line Obstacle 67

Log Dragging 54

Lope 16

## M

Measurement 11, 165

Height classifications 38

Meter 45

Misconduct 7, 14, 68, 137

Mule 15

Mule Pulls 137

Mulemanship 83

Multiple Hitch Driving 47

Multiple Hitch Obstacle Driving 48

## N

Non-point 9, 20, 21

Novice 19

## O

Obstacle Driving 46, 167

    Multiple Hitch 48, 167

    Single Hitch 46

Official identification 15

Old Clothes Race 123

Open 22

## P

Parade Class 49

Park gait 44, 165

Patterns/diagrams 10, 40, 41, 52, 57,

    Cloverleaf 116

    Jumps 107

Log Drag 161-162  
 Obstacles for driving classes 170  
 Pole Bending 117, 173  
 Ranch Riding 95  
 Reined Working Donkey 80- 82  
 Reining 71-79  
 Showmanship 181, 183  
 Snigging 55,  
 Tally Sheet 128  
 Trail obstacles 65, 177  
 Turn on Forehand 63  
 Western Riding 88, 89  
 Working cow mule 134, 135, 136  
 Pee Wee 17, 146, 183  
 Points 12,13,  
 Pole Bending 116  
 Potato Race 119  
 Prohibited equipment  
     Boots prohibited 163  
     Driving Classes 36  
     English Classes 35  
     Speed Events 35  
     Western performance 30  
 Prohibited Obstacles 168  
 Protective head gear 26, 122, 144  
 Protests 7, 21, 142  
 Pull rules 137  
 Pylon Alley 118  
 :  
 Q  
 Quarter Method (Showmanship) 42, 43, 182  
  
 R  
 Recorded Green 57  
 Refunds 7  
 Reined Working Donkey 81, 83  
 Reining 67, 72-78, 84  
     Freestyle Reining 111  
 Reinsmanship 49  
     Driving 166

Rescue Race 124  
Reversing 44, 57, 92, 96, 165  
Ride A Buck 121  
Ring steward 7, 8, 35, 38, 44, 90, 127, 157, 165, 167, 178  
Road gait 44, 165  
Rule reference (AQHA) 7  
Run, Ride and Lead 125

## S

Sack Race 123  
Saddle Seat. See English Pleasure  
Sanctioned show 7, 8, 20, 140, 141  
Select Division 25, 26  
Show flyer 8, 9, 18, 19  
Show management 7  
Show procedures 8  
Showmanship Classes 40, 178  
    Pattern 180  
Side Saddle 112  
Single Hitch Driving 45  
Single Hitch Obstacle Driving 46  
Single Hitch Timed Driving 47  
Snaffle bit 28, 58, 93, 164  
Snigging 52, 54, 143, 149, 158, 159, 160  
Specialty Performance Class Rules 4, 108, 109, 110,  
    111  
Speed Event Classes 26, 35, 114, 115, 117, 118, 119,  
    120  
Stake Race 124,  
Steer Stopping 129  
Straight-Away Barrels 114  
Sub-Youth 17  
    Assistant 59, 60, 145  
Sulkies 164

## T

Team Roping 11, 13, 130  
Thimbles 36, 164  
Ties 13, 169  
Timed Driving 47

Timed events. See Speed Events  
Timers 114, 127, 129, 143  
Trail Class 4, 57, 67, 125, 149, 175  
Trimming 41  
Trot 7, 9, 17, 18, 22, 25, 26, 44, 45, 47, 59, 61, 91,  
150, 156, 157, 164, 165, 166, 174, 178  
Tunnel Race 121  
Turn on Haunches 63  
Two-handed 21, 22, 28, 56, 111, 132, 163

## V

Versatility Ride and Drive 3, 51, 177

## W

Walk 16, 41, 44, 67, 100, 165, 167  
Western Mulemanship/Donkeymanship 83  
Western Performance Classes 22, 28  
Western Pleasure 57  
Western Riding 85  
Working Cow Mule 131